



Enhanced DE-2500 System Now Available

DE SERIES

Programmable Safety Shutdown, Monitoring and Control Products with Analog Input Capabilities

- A state-of-the-art family of products specifically designed to protect, monitor and control critical rotating machinery, such as engine or motor-driven compressors, pumps and generators.
- Two product choices to fit virtually any application.
- DE-2200 and 2500 models track operating hours and annunciate required service intervals of 11 different items.
- DE-2500 model automatically and continuously optimizes compressor efficiency and throughput via speed and capacity control feature and also incorporates automatic start capability.
- Features and benefits common to all models
 - Accept both analog and discrete inputs
 - Continuously monitor safety switches and analog set-points for correct operation, initiate alarm or shutdown if required, and provide alphanumeric display of cause or fault
 - Alphanumeric displays and process screens show four values simultaneously in both digital and bar-graph format
 - Capable of remote communication of operating condition, speed, operating hours, and process parameters via satellite, radio, cellular or telephone
 - Internal data log of 100 time-spaced “snap shots” of monitored data
 - Easily configurable via included Windows™-based terminal programs
 - Plug-in memory allows transfer of configuration information to a spare unit if necessary, eliminating the need for a PC and skilled technician in the field
 - Designed for harsh environments and wide temperature ranges
 - CSA-certified for use in Class I, Division 2, Groups C and D hazardous areas

The DE Series of products have been designed utilizing the latest state-of-the-art technology and surface-mount assembly techniques to provide users of compressors and other critical machinery with a sophisticated yet reliable means of protecting and controlling both the prime mover and load machine. The DE-2500 model is specifically designed to protect and control both reciprocating and screw compressors. Comprehensive communications between the DE device in the field and a central monitoring system further complement these capabilities.

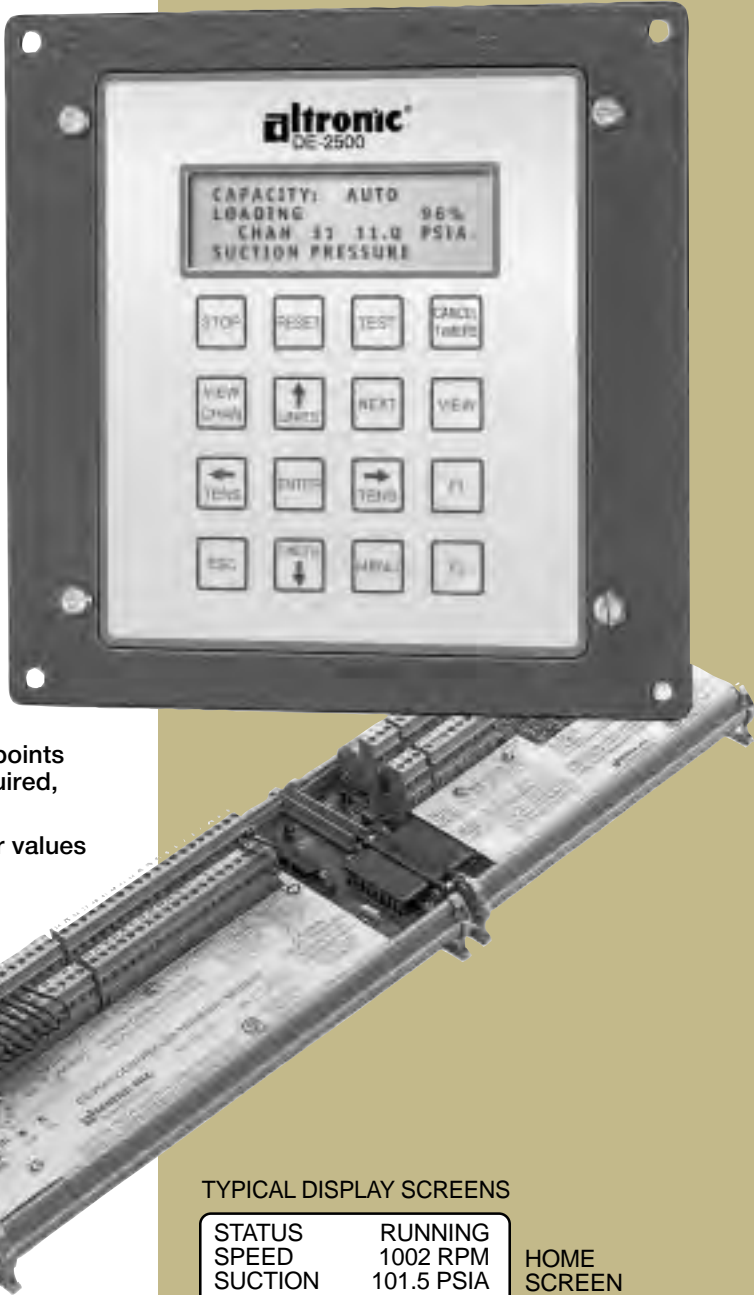

TYPICAL DISPLAY SCREENS

| | | |
|------------|------------------|-------------------|
| STATUS | RUNNING | HOME SCREEN |
| SPEED | 1002 RPM | |
| SUCTION | 101.5 PSIA | |
| DISCHARGE | 300 PSIG | |
| Ps | SUCTION 600 PSI | PROCESS DIGITAL |
| Pi 1 | INTSTG1 850 PSI | |
| Pi 2 | INTSTG2 1100 PSI | |
| Pd | DISCHRG 1200 PSI | |
| SUCTION L | | PROCESS BAR GRAPH |
| DISCHRG | | |
| OIL TEMP L | | |
| ENG MAN L | | |



CERTIFIED CLASS I, DIVISION 2, GROUPS C and D



DE-2200 OVERVIEW

Safety shutdown, monitoring, and communications

- “Panel-in-a-box” system is designed to offer complete prime mover and process monitoring and protection.
- Monitors up to thirty-one safety shutdown points (sixteen normally-open or normally-closed switches plus fifteen analog inputs, each of which has two setpoints). Any point can be configured for Class A, B, or C operation.
- System allows for direct connection of both thermocouples and transducers for temperature and process pressure monitoring, or for other process parameters.
- Communicates monitored parameters, fault status, and operating information via RS-232 or RS-485 in either Modbus RTU or ASCII protocols.
- Ideal retrofit package to update and add remote communication to existing field equipment.

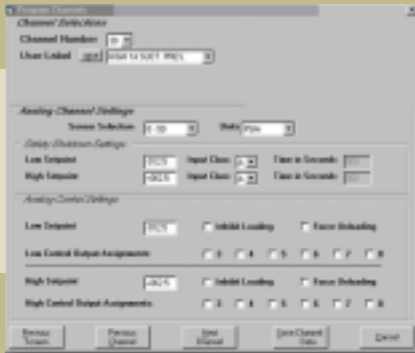

An easy to use, Windows™-based Terminal Program is included with each DE system for simple system configuration and remote monitoring.



DE-2500 OVERVIEW

Safety shutdown, monitoring, compressor throughput control, and communications

- Contains all of the features of the DE-2200 system described above plus auto-start and compressor throughput control capabilities.
- Integrated DE-2500 system is ideal for safety shutdown and control for both screw-style and reciprocating compressors.
- Reduces operating costs by continuously optimizing the compressor capacity for actual operating conditions.
- Incorporates two analog PID loops and one pulsed, digital PID loop to control the speed of the prime mover/compressor as well as to position the compressor capacity control valves (such as screw compressor slide valves).
- The second generation, DE-2500 system offers expanded PID control, differential pressure/temperature monitoring, direct thermocouple input monitoring, and improved program download speeds among many other new capabilities.
- Automatic load inhibit and/or forced unload to protect the controlled/monitored equipment from potentially destructive operation.
- Incorporates 12 digital outputs (4 solid-state relay, 8 discrete) for automatic start and/or auxiliary control functions.

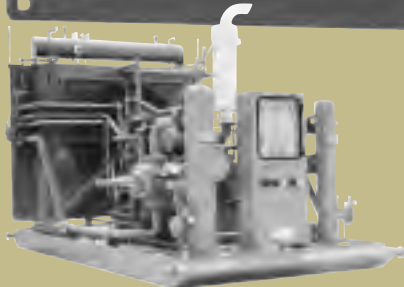

DE-2200 DESCRIPTION AND OPERATION

The CSA-certified DE-2200 system comprehensively protects critical rotating equipment such as reciprocating engines, pumps, and compressors, by continuously monitoring up to thirty-one points on the prime mover and/or the associated process. Each DE-2200 system can monitor up to sixteen normally-open or normally-closed switch contacts (typically from skid-mounted level or vibration switches) as well as up to fifteen analog inputs (of which up to seven can be used as inputs for J or K thermocouples). The system consists of a front panel-mounted Display Unit, and back panel, DIN-rail mounted Power Supply and Terminal Modules.

In the event of a fault, an alarm or shutdown is generated and its cause is displayed in plain language on the built-in 4 line by 20 character backlit LCD display. Depending upon system configuration, each point can be configured on fault to trip one of four digital outputs for shutdown or other control functions. Cause of fault, operating mode, speed, operating hours, and the value of all monitored analog inputs is continuously

available on the RS-232/485 serial port in either Modbus RTU or ASCII protocols. An easy-to-use Windows™-based Terminal Program is included with each DE-2200 system for configuration and monitoring.

Convenient serial access to the monitored data collected by the DE-2200 system expands the system's capabilities to include remote data acquisition. Monitored information can be relayed to personal computers or PLC's, or transmitted via telephone, cellular service, radio, or satellite monitoring and data transmission systems. A built-in data logging capability within the DE-2200 locally records up to 100 time-spaced data records containing all of the critical operating and analog input values (temperatures, pressures, etc.) in a rolling log format. This information has been found useful to many users whom either access the data locally or remotely for an analysis of events leading up to a shutdown.

DE-2500 DESCRIPTION AND OPERATION

The innovative, CSA-certified, DE-2500 system integrates all of the safety shutdown and monitoring functionality resident in the DE-2200 system with full system auto-start and compressor throughput (capacity) control. Designed to maximize the efficiency of the controlled compressor (screw or reciprocating), this full-featured system offers engine/compressor sequencing and load control, and can maintain peak compressor performance despite changes in ambient or field conditions. By operating the compressor continually at its most efficient point and at the required capacity, significant cost savings can be achieved.

The DE-2500's two analog PID loops, (as well as its digital pulsed outputs) used to control compressor slide or turn valves, act in concert to achieve a setpoint which is generally expressed as a desired suction, discharge, or manifold pressure. In typical operation, the DE-2500 system starts and warms-up the engine/compressor, raises it to load-carrying speed, then applies load by actuating the compressor slide valves or other capacity control devices. Should the control setpoint not be met at the minimum load carrying speed, the compressor speed is then automatically raised in an effort to meet the desired process pressure setpoint. This control strategy is governed by a number of user-adjustable load and speed limits which

can inhibit the application of additional load beyond what is deemed to be safe, can force the system to shed load, and can shutdown in the event that a maximum speed is exceeded.

The DE-2500 now features two operating modes: standard and enhanced. In the standard mode, all traditional DE-2500 capabilities are retained. When operating in the enhanced mode, significant new features and options are available to the user, including the ability to directly monitor J or K thermocouples, expanded customization controls for the control PID loops, the ability to implement on-board differential temperature and differential pressure monitoring, keyboard access to input point characteristics (class and lock-out time), and dramatically improved program download speeds. As is customary with Altronic products, full backward compatibility with the existing DE-2500 systems is assured.

Full RS-232/RS-485 Modbus and ASCII communications are supported in the DE-2500 system for use in conjunction with local and/or remote monitoring and control systems. An advanced, Windows™-based terminal program, combined with keypad access to many functions, allows for easy system setup.

DE-2200 SERIES SYSTEM DIAGRAM

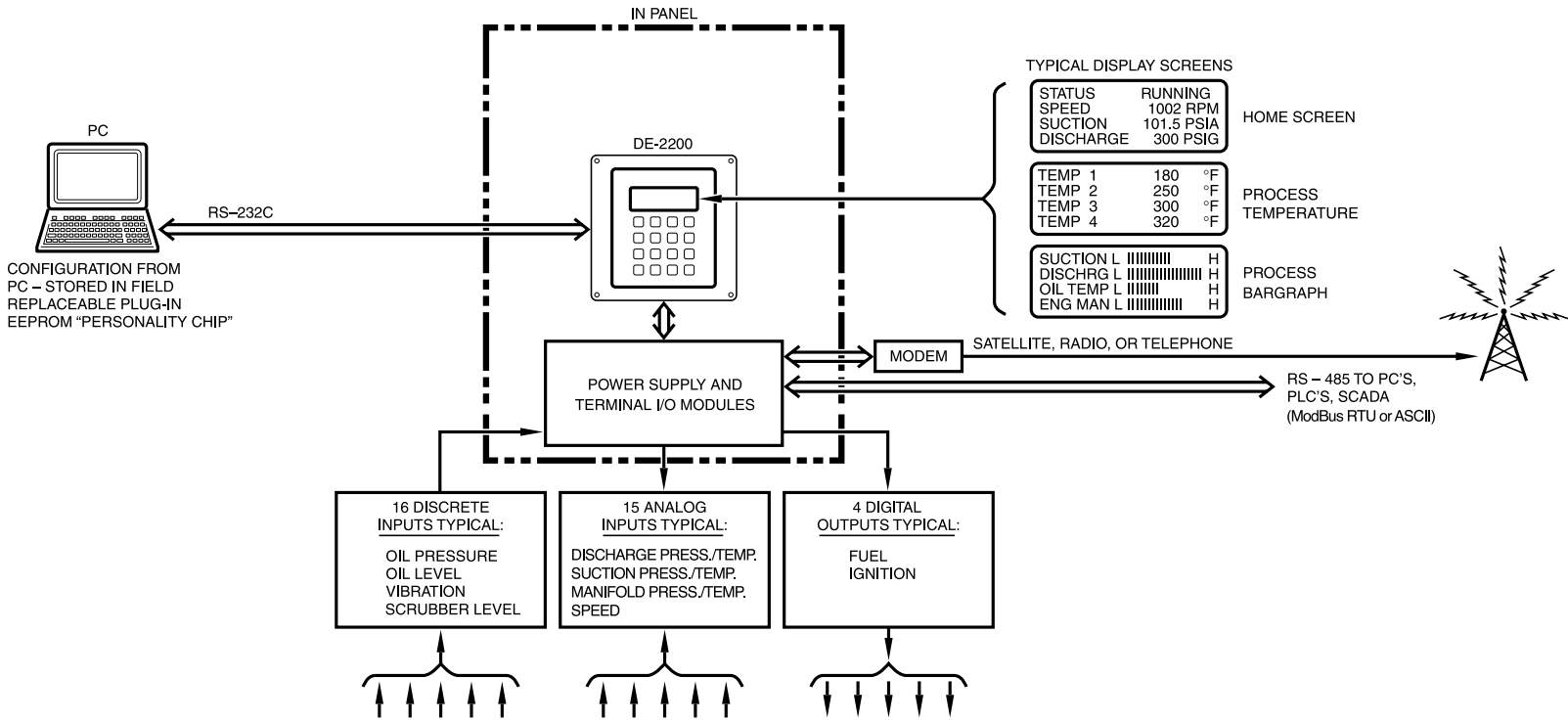

DE-2500 SERIES SYSTEM DIAGRAM

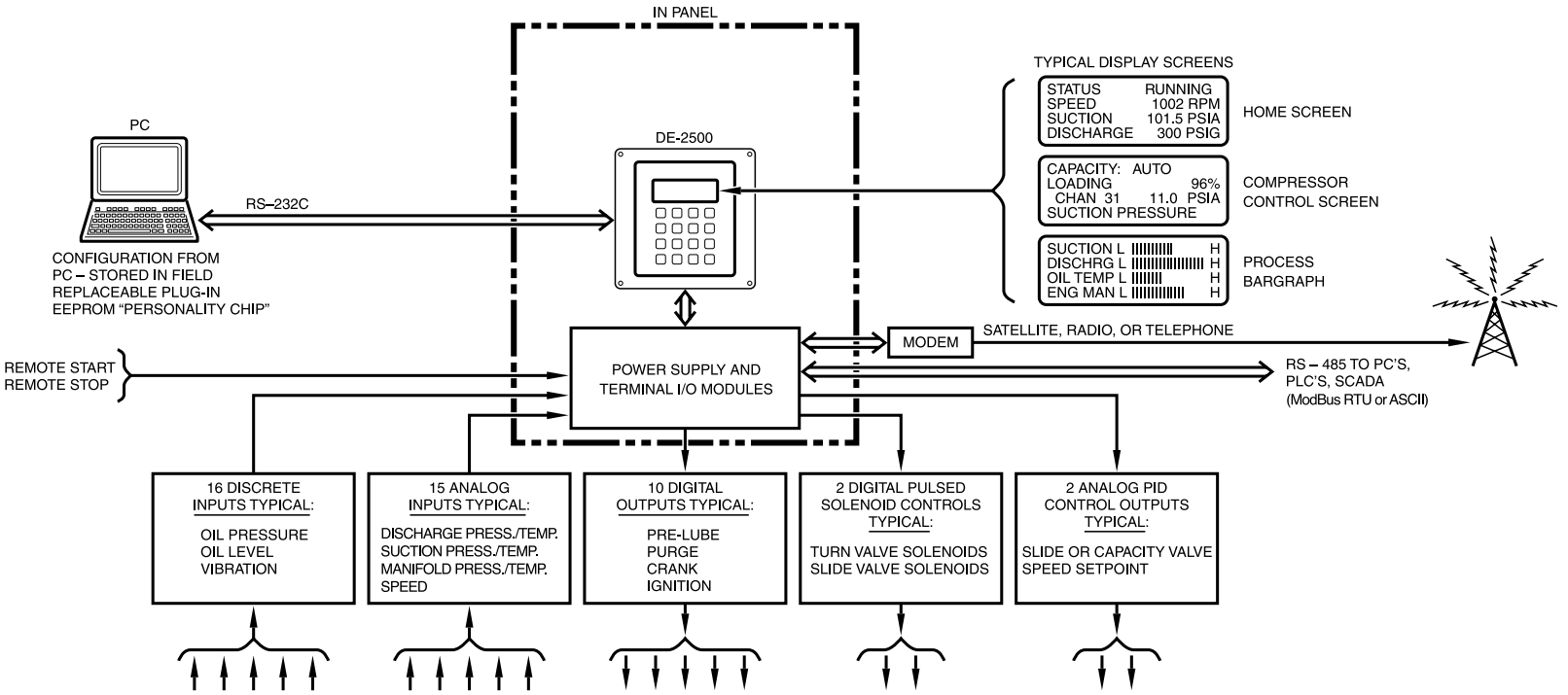

SUMMARY OF DE SERIES FEATURES AND SPECIFICATIONS

| ITEM | DE-2200 SYSTEM | DE-2500 SYSTEM |
|------------------------------|---|---|
| SHARED FEATURES | Safety shutdown Local/remote communication 100 record data log Alphanumeric and bar-graph displays | |
| SPECIAL FEATURES | Pre/post lube control 11-item service meter | Auto-start/Compressor Control Logic 11-item service meter |
| DIGITAL INPUTS | 16 switch contacts 1 remote stop (all are N.O. or N.C.) | 16 switch contacts 1 remote start 1 remote stop (all are N.O. or N.C.) |
| DIGITAL OUTPUTS | 4 solid state relays | 4 solid state relays 6 digital switch (60V., 2A.) 2 pulsed switch (60V., 2A.) |
| ANALOG INPUTS | 7 0-5 Vdc 7 0-5 Vdc or J-K TC 1 frequency | 7 0-5 Vdc 7 0-5 Vdc or J-K TC 1 frequency |
| ANALOG OUTPUTS | None | 2 4-20 mA PID loops |
| SERIAL PORTS | 1 RS-232 and 2 RS-485 | |
| DISPLAY | 4 line x 20 character alphanumeric, backlit | |
| SCAN RATE | 15 per second (analog channels on DE-2000 - 6 per sec.) | |
| AMBIENT TEMP. | -31°F to + 176°F / -35°C to +80°C | |
| POWER REQUIRED | 12 to 24 Vdc, 15 watts maximum | |
| HAZARDOUS AREA CERTIFICATION | CSA Certified Class 1, Division 2, Groups C and D | |

DE Series Data Logging and Communications

The DE Series products are designed to operate in a communication environment. The serial communications interfaces provide the user access to critical data, both locally and from remote locations, allowing predictive scheduled maintenance and/or dispatch of repair personnel with the correct parts. DE units can also initiate a call-out in the event of a fault. ModBus and ASCII protocols are supported in both models.

At the core of the DE Series communications functions are the data logs (see table at right). These snapshots of data are taken at user-defined intervals, and are a compilation of the analog values being monitored by the DE, plus unit speed, status, and complete information on the first fault that caused a system shutdown (identity, value, date, time). Using the Terminal Program, data log information can be downloaded locally to a portable PC or communicated remotely via telephone, satellite or radio. Altronic's CompressorWatch.com system couples satellite or cellular technology with Web-based reporting, e-mail and paging to give users access to critical data no matter where they or the reporting equipment are located.

An integral data analysis/trending package that is included with the DE Terminal Software can display and graph this data for inspection and analysis. The sample graph shown at right depicts a shutdown that was caused by compressor discharge temperature exceeding its 325° setpoint, followed by a restart.

SAMPLE DATA LOG AND GRAPH

| | |
|--------------------------------|---|
| COMP. STATION #01 GIRARD, OHIO | User entered data log header describing location |
| 001 10333 HRS | Record number and running hours |
| 10-19-1998 9:46 AM | Date/time the record information was collected |
| STATUS RUNNING | Normal home screen status line |
| SPEED 925 RPM | Normal home screen, line two |
| SUCTION 102.3 PSIA | Normal home screen, line three |
| DISCHARGE 300 PSIG | Normal home screen, line four |
| PRESS 1 102.3 PSIG | First view process screen, line one |
| PRESS 2 355 PSIG | First view process screen, line two |
| PRESS 3 250 PSIG | First view process screen, line three |
| PRESS 4 275 PSIG | First view process screen, line four |
| TEMP 1 55 EF | Second view process screen, line one |
| TEMP 1 170 EF | Second view process screen, line two |
| TEMP 1 180 EF | Second view process screen, line three |
| TEMP 1 190 EF | Second view process screen, line four |
| TEMP 1 220 EF | Third view process screen, line one (enhanced 2500) |
| PRESS 5 22 PSIA | Third view process screen, line two (enhanced 2500) |
| USER LABEL | Third view process screen, line three (enhanced 2500) |
| USER LABEL | Third view process screen, line four (enhanced 2500) |
| 1ST FAULT HIGH | First fault indication when fault occurs |
| CHAN A3 500 PSI | Channel number and value of first fault |
| HIGH INTERSTAGE PRESS | 20 character label associated with the first fault |
| 10-19-1998 9:46 AM | Date and time of the first fault |

* If a view process screen line is not programmed in the controller, the line will be blank.
 ** These lines will be blank when there are no faults.

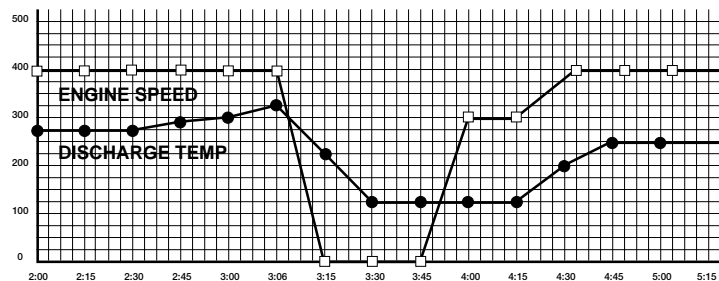

DIMENSIONS (DE-2500 shown)

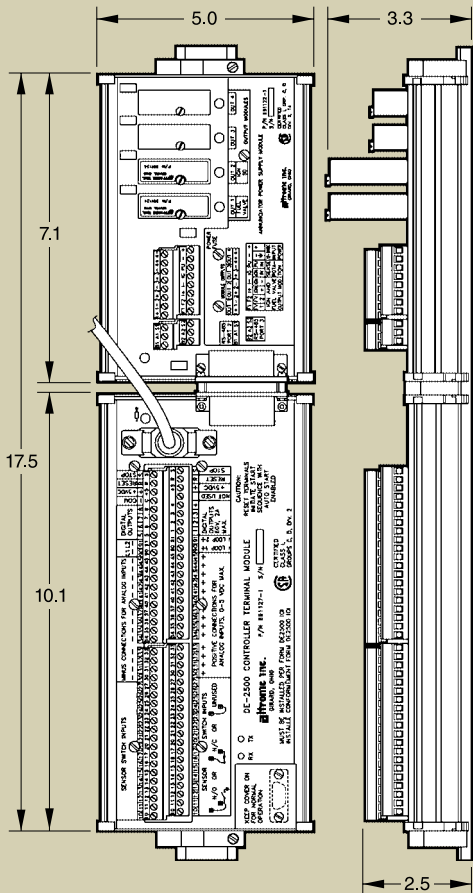
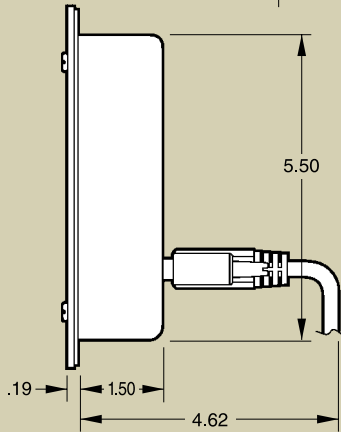
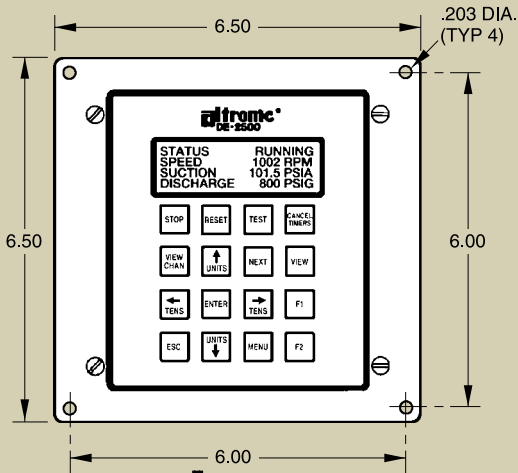

TO ORDER

DISPLAY MODULE

| | |
|----------------------|---------|
| DE-2200 system | DE-2200 |
| DE-2500 system | DE-2500 |

POWER SUPPLY MODULE

| | |
|----------------------|----------|
| All DE systems | 691122-1 |
|----------------------|----------|

TERMINAL MODULE

| | |
|----------------------|----------|
| DE-2200 system | 691136-1 |
| DE-2500 system | 691127-1 |

CABLE ASSEMBLIES (common to all DE systems)

| | |
|---|-----------|
| Display to Terminal Module (DB-25) | 693115-1 |
| Power Supply to Terminal Module (DB-25) | 693115-1* |
| Display Module RS-232 Port (DB-9) | 693116-1 |

*Use only if Power Supply and Terminal Modules are mounted separately.

OUTPUT RELAY MODULES (common to all DE systems)

| | |
|--------------------------------|--------|
| C.D. Fuel Valve/Ignition | 691124 |
| 5-48 Vdc, 5.0 A. | 691125 |
| 5-60 Vdc, 2.0 A. | 691056 |
| 5-200 Vdc, 0.67 A. | 691066 |
| 24-280 Vac, 2.0 A. | 691065 |

AVAILABLE ALTRONIC TRANSDUCERS

PRESSURE TRANSDUCERS

| | |
|------------------------------|-------------|
| 0-50 psia | 691204-50 |
| 0-100 psia | 691204-100 |
| 0-300 psia | 691204-300 |
| 0-500 psia | 691204-500 |
| 0-100 psig/0-680 Kpa | 691201-100 |
| 0-300 psig/0-2040 Kpa | 691201-300 |
| 0-500 psig/0-3400 Kpa | 691201-500 |
| 0-1000 psig/0-6800 Kpa | 691201-1000 |
| 0-2000 psig/0-136 bar | 691201-2000 |
| 0-5000 psig/0-340 bar | 691201-5000 |

TEMPERATURE TRANSDUCERS

| | |
|--|------------|
| Range: +5° F to 350° F / -15° C to 176° C (±3° F / ±2° C) | |
| 1.75" length | 691202-300 |
| 5.75" length | 691203-300 |
| Range: -40° F to 450° F / -40° C to 232° C (±6° F / ±4° C) | |
| 1.75" length | 691212-450 |
| 5.75" length | 691213-450 |

TRANSDUCER CABLES

| | |
|---------------------|-----------|
| 5 ft. length | 693008-5 |
| 25 ft. length | 693008-25 |
| 50 ft. length | 693008-50 |

altronic[®]
inc.

712 TRUMBULL AVE. / GIRARD, OHIO 44420
PHONE: (330) 545-9768 / FAX: (330) 545-9005
Email: sales@altronicinc.com / Web: www.altronicinc.com