

**REQUIRED ITEMS:**

**A: CPU-2000 LOGIC MODULE, 1 PER SYSTEM**

PART NO.	DESCRIPTION
291100-1 W620004-V2.1	Logic Module Firmware Option: ModBus communication and dual secondary diagnostics*
291100-1S W620004-V2.1S1	Logic Module, no test function Firmware Option: ModBus communication and dual secondary diagnostics*

\*NOTE: To update older units to these features, order firmware upgrade kit 620003-V2.1 or 620003-V2.1S1 (no test function).

**MEMORY PART NO. CODE (see application listings). Example: F2A360.HS012#005**

DESIGNATOR	DESCRIPTION
F	Letter in alphabet corresponding to no. of engine cylinders: C=3, D=4, E=5, F=6, G=7, H=8, I=9, J=10, L=12, N=14, P=16, R=18, T=20, X=24, Z=32
2	Engine stroke-cycle: 2 = 2-cycle 4 = 4-cycle 6 = 2-cycle with two outputs for each cylinder/2nd plug cutout feature 8 = 4-cycle with two outputs for each cylinder/2nd plug cutout feature
A	Altronic firing pattern code: A = even firing pattern, Other letters = odd firing pattern
360	No. of sensed teeth or holes: 360 = 360 teeth or holes
H	Memory series code: H = CPU-2000
S	Timing curve code: A = 48 degree retard for 4-20mA input, 3 degrees retard default timing B = 36 degree retard for 4-20mA input, 3 degrees retard default timing C = 24 degree retard for 4-20mA input, 3 degrees retard default timing N = special range vs. 4-20mA or RPM, non-factory programmed S = special range vs. 4-20mA or RPM, factory programmed X = no timing curve programmed
012	Special timing curve version number
#005	Feature code (add numbers chosen; only one choice permitted per feature): 001 = 1-step retard when misc. input is grounded 016 = 1-step retard when rpm is less than 200 002 = Max. energy when misc. input is grounded 032 = Max. energy when rpm is less than 200 004 = Extended firing when misc. input is grounded 064 = Extended firing when rpm is less than 200 008 = Fire 2nd plug only when misc. input is grounded 128 = Fire 2nd plug only when rpm is less than 200 Example: 005 = feature 001 + feature 004
2nd example: L4A180.FC#080	12-cylinder, 4-cycle 45°-75° firing pattern (L4H) 360 sensed teeth 24° timing range for 4-20mA Feature codes 016 and 064 selected

## CPU-2000 DIGITAL IGNITION SYSTEM

### REQUIRED ITEMS:

#### B: CPU-2000 OUTPUT MODULE, 1 PER SYSTEM

PART NO.	DESCRIPTION
291116-1	Output Module, 16 outputs
291132-1	Output Module, 32 outputs (standard)
291132-2	Output Module, 32 outputs (special - see NOTE below)

**NOTE:** Optimum results are obtained with the optional Diagnostic Module if each ignition coil is connected to a separate primary output. To realize this on 9-16 cylinder engines with two ignition coils per cylinder, use:

- Output Module 291132-1 where the application listing indicates note 2.
- Output Module 291132-2 where the application listing indicates note 3. This Output Module allows engines with close firing angles to fire two outputs simultaneously. Note that the multi-strike feature is NOT available in Output Module 291132-2.

#### C: CPU-2000 DIAGNOSTIC MODULE (OPTIONAL), 1 ITEM FROM EACH CATEGORY PER SYSTEM

PART NO.	DESCRIPTION
<i>Diagnostic Module:</i>	
291105-1 W601868-V2.1	Diagnostic Module Firmware Option: ModBus communication and dual secondary diagnostic
<i>Cable Assembly, Diagnostic Module to Output Module:</i>	
293031-24	Cable, shielded, 180° connector, 24" conduit
293031-48	Cable, shielded, 180° connector, 48" conduit
293031-72	Cable, shielded, 180° connector, 72" conduit
<i>Cable Assembly, Diagnostic Module to Junction Box:</i>	
593050	Pickup Cable, unshielded, 90° connector, 48" conduit, 50 ft. cable
593052-L	Pickup Cable, shielded, 180° connector, L" conduit, 25 ft. cable L = 6", 12", 18", 24", 36", 48", 72", 96"
593057-L	Pickup Cable, shielded, 90° connector, L" conduit, 25 ft. cable L = 6", 12", 18", 24", 36", 48", 72", 96"

**NOTE:** Logic Module EPROM (601707) and Microprocessor (601747) must be Version 2.0 or higher to operate properly with the Diagnostic Module. To update older units to the latest features (Version 2.1), order firmware upgrade kit 620003-V2.1 or 620003-V2.1S1 (no test function).

#### D: CABLE ASSEMBLY, LOGIC MODULE TO OUTPUT OR DIAGNOSTIC MODULE, 1 PER SYSTEM

PART NO.	DESCRIPTION
293030-25	Cable, shielded, 180° connector, 72" conduit, 25' leads
293030-50	Cable, shielded, 180° connector, 72" conduit, 50' leads
293030-75	Cable, shielded, 180° connector, 72" conduit, 75' leads

#### E: OUTPUT HARNESS, CPU-2000 UNIT TO JBOX, 1 PER SYSTEM

PART NO.	DESCRIPTION
293023-8	Harness, shielded, 90° connector, 48" conduit, 72" leads, 8 outputs
293023-16	Harness, shielded, 90° connector, 48" conduit, 72" leads, 16 outputs
293026-8	Harness, shielded, 90° connector, 84" conduit, 120" leads, 8 outputs
293026-16	Harness, shielded, 90° connector, 84" conduit, 120" leads, 16 outputs
293027-8	Harness, shielded, 90° connector, 144" conduit, 180" leads, 8 outputs
293027-16	Harness, shielded, 90° connector, 144" conduit, 180" leads, 16 outputs
293028-8	Harness, shielded, 90° connector, 96" conduit, 180" leads, 8 outputs
293028-16	Harness, shielded, 90° connector, 96" conduit, 180" leads, 16 outputs

**NOTE:** Output Module 291116-1 requires one of the above harnesses.  
Output Modules 291132-1 and 291132-2 require two harnesses 29302x-16.

**F: MAGNETIC PICKUP, 2 PER SYSTEM**

PART NO.	DESCRIPTION
<i>Trigger Magnet (camshaft mount):</i>	
691118-1	Magnetic Pickup, 5/8"-18 thread x 1.75" threaded body length
691118-2	Magnetic Pickup, 5/8"-18 thread x 2.50" threaded body length
691118-3	Magnetic Pickup, 5/8"-18 thread x 3.00" threaded body length
691118-4	Magnetic Pickup, 5/8"-18 thread x 4.50" threaded body length
691118-6	Magnetic Pickup, 5/8"-18 thread x 6.00" threaded body length

**G: CABLE ASSEMBLY, MAGNETIC PICKUP, 2 PER SYSTEM**

PART NO.	DESCRIPTION
593048-L	Pickup Cable, shielded, 180°connector, L" conduit, 50 ft. cable L = 12", 18", 24", 36", 48", 72", 96"
593054-L	Pickup Cable, shielded, 90°connector, L" conduit, 50 ft. cable L = 12", 18", 24", 36", 48", 72", 96"
593048A-L	Pickup Cable, shielded, 180°connector, L" conduit, 100 ft. cable L = 24", 48", 72", 96"
593054A-L	Pickup Cable, shielded, 90°connector, L" conduit, 100 ft. cable L = 24", 48", 72", 96"
693104-1	Pickup Cable, unshielded, 180°connector, 10 ft. cable
693104-2	Pickup Cable, unshielded, 180°connector, 20 ft. cable
693104-3	Pickup Cable, unshielded, 180°connector, 30 ft. cable
693104-4	Pickup Cable, unshielded, 180°connector, 40 ft. cable
693104-5	Pickup Cable, unshielded, 180°connector, 50 ft. cable

NOTE: Above shielded cables are CSA certified for Class I, Divison 2, Group D hazardous locations when used with other applicable CSA-certified Altronic components

**H: CYCLE TRIGGER (4-CYCLE ENGINES ONLY), 1 FROM EACH CATEGORY BELOW PER SYSTEM**

PART NO.	DESCRIPTION
<i>Trigger Magnet (camshaft mount):</i>	
260604	Trigger Magnet, 3/4" dia. x 8mm thread (max. rotating circle is 15" dia.)
260605	Trigger Magnet, 3/4" hex x 8mm thread (max. rotating circle is 15" dia.)
720002	Trigger Magnet, 3/8" hex x 8mm thread (max. rotating circle is 6" dia.)
<i>Hall-effect Pickup:</i>	
591014-2	Hall-effect Pickup, 5/8"-18 thread x 2.5" threaded body length
591014-4	Hall-effect Pickup, 5/8"-18 thread x 4.0" threaded body length
<i>Pickup Cable:</i>	
593050	Pickup Cable, unshielded, 180° connector, 25 ft. cable
593052-L	Pickup Cable, shielded, 180° connector, L" conduit, 25 ft. cable L = 6", 12", 18", 24", 36", 48", 72", 96"
593057-L	Pickup Cable, shielded, 90° connector, L" conduit, 25 ft. cable L = 6", 12", 18", 24", 36", 48", 72", 96"

NOTE: Above shielded cables are CSA-certified for Class I, Divison 2, Group D hazardous locations when used with other applicable CSA-certified Altronic components

## CPU-2000 DIGITAL IGNITION SYSTEM

---

### REQUIRED ITEMS:

#### I: IGNITION COILS, 1 PER SPARK PLUG

PART NO.	DESCRIPTION
291001	Unshielded Coil
291001-S	Shielded Coil
591008	Integral Coil, 1"-20 thread x 5.6" length

**NOTE:** IF RETROFITTING FROM AN ALTRONIC II-CPU SYSTEM, ITEMS E, F, G, H AND I ABOVE CAN BE REUSED.

CPU-2000 SYSTEM DIAGRAM

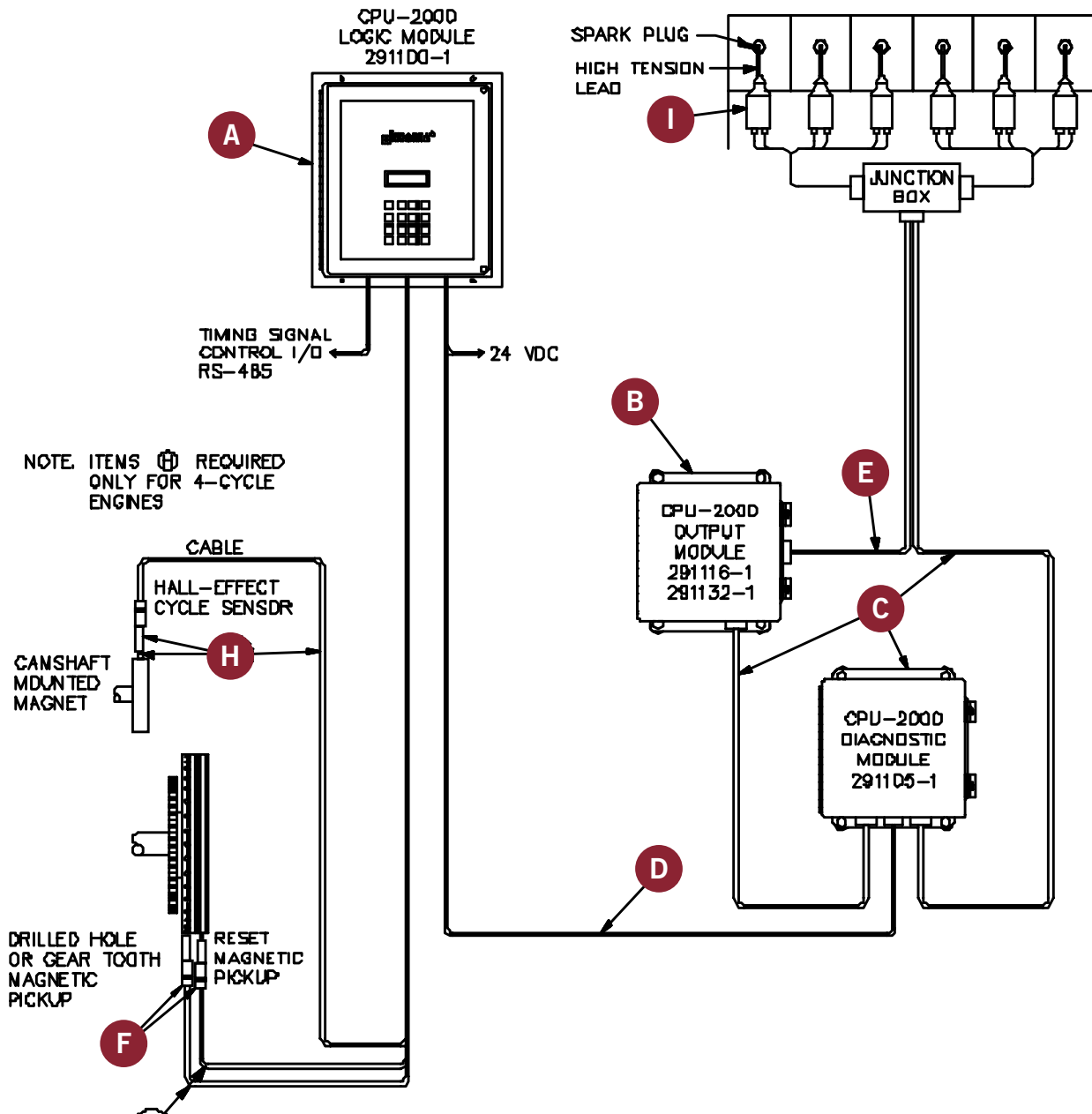

## CPU-2000 DIGITAL IGNITION SYSTEM

ENGINE MODEL NO.	FIRING PATTERN	CPU-2000 OUTPUT MOD	MEMORY CODE NO.	QTY. COILS	NOTES	
<b>CLARK</b>						
BA, HBA, HBA-T, HLA	- 5	72°	291116-1	E2Axxx.HA	10	1
	- 6	60°	291116-1	F2Axxx.HA	12	1
	- 8	67.5°- 22.5°	291116-1	H2Cxxx.HA	16	1
	- 1	36°	291116-1	J2Axxx.HA	20	2
MA, HMA, HMB, TMB	- 4	90°	291116-1	D2Axxx.HA	4 / 8	1
	- 6	60°	291116-1	F2Axxx.HA	6 / 12	1
	- 8	22.5°-67.5°	291116-1	H2Hxxx.HA	8 / 16	1
	- 10	36°	291116-1	J2Axxx.HA	10 / 20	2
RA, HRA, HRA-T, HSRA	- 32	120°	291116-1	C2Axxx.HA	6	1
	- 4	90°	291116-1	D2Axxx.HA	8	1
	- 5	72°	291116-1	E2Axxx.HA	10	1
	- 6	60°	291116-1	F2Axxx.HA	12	1
	- 8	45°	291116-1	H2Axxx.HA	16	1
TCV, TCVA, TCVC TCVD, TPV	- 10	50°-22°	291116-1	J2Txxx.HA	20	2
	- 12	50°-10°	291116-1	L2Txxx.HA	24	3
	- 16	22.5°-27.5°-17.5°	291116-1	P2Hxxx.HA	32	2
	- 20	14°-22°	291132-1	T2Hxxx.HA	40	6
TLA, TLAC, TLAD, TRA	- 5	72°	291116-1	E2Axxx.HA	10	1
	- 6	60°	291116-1	F2Axxx.HA	12	1
	- 8	67.5°-22.5°	291116-1	H2Cxxx.HA	16	1
	- 10	36°	291116-1	J2Axxx.HA	20	2
TVM	- 10	50°-22°	291116-1	J2Txxx.HA	20	6
	- 12	50°-10°	291116-1	L2Txxx.HA	24	6
VRA	- 12	8-55-2-55	291116-1	L2Qxxx.HA	24	6
	- 16	Contact Factory	291116-1	P2xxxx.HA	32	6
	- 20	Contact Factory	291132-1	T2xxxx.HA	40	6
<b>COOPER BESSEMER</b>						
GMV (short stroke)	- 4	63°-117°	291116-1	D2Fxxx.HA	4	
	- 6	63°-57°	291116-1	F2Fxxx.HA	6	
	- 8	63°-27°	291116-1	H2Fxxx.HA	8	
	- 10	63°-9°	291116-1	J2Fxxx.HA	10	3
GMV, GMVA, GMVC GMVE, GMVG, GMVH (flat crank)	- 4	60°-120°	291116-1	D2Bxxx.HA	8	1
	- 6	60°	291116-1	F2Axxx.HA	12	1
	- 8	60°-30°	291116-1	H2Txxx.HA	16	1
	- 8	0-60-0-120	291116-1	H2Nxxx.HA	16	6
	- 10	60°-12°	291116-1	J2Bxxx.HA	20	3
- 12	0°-60°	291116-1	L2Rxxx.HA	24	6	

COOPER BESSEMER CONTINUED ON THE NEXT PAGE

ENGINE MODEL NO.	FIRING PATTERN	CPU-2000 OUTPUT MOD	MEMORY CODE NO.	QTY. COILS	NOTES	
<b>COOPER BESSEMER (continued)</b>						
GMW, GMWA, GMWC	- 6	36°- 84°	291116-1	F2Dxxx.HA	12	1
GMWE, GMWH	- 8	36°- 54°	291116-1	H2Dxxx.HA	16	1
	- 10	36°	291116-1	J2Axxx.HA	20	2
	- 12	36°- 24°	291116-1	L2Dxxx.HA	24	2
	- 16	36°- 9°	291116-1	P2Dxxx.HA	32	3
GMX, GMXA, GMXB	- 4	63°- 117°	291116-1	D2Fxxx.HA	4	1
GMXC,GMXD,GMXE	- 6	63°- 57°	291116-1	F2Fxxx.HA	6	1
	- 8	63°- 27°	291116-1	H2Fxxx.HA	8	1
	- 10	63°- 9°	291116-1	J2Fxxx.HA	10	3
	- 12	0-63-0-57	291116-1	L2Xxxx.HA	12	6
JS, LS	- 6	120°	291116-1	F4Axxx.HC	12	1
	- 6	4°- 116°	291116-1	L4Sxxx.HC	12	
	- 8	90°	291116-1	H4Axxx.HC	16	1
	- 8	4°- 86°	291116-1	P4Sxxx.HC	16	
LSV	- 12	36°- 84°	291116-1	L4Lxxx.HC	24	2
	- 12	4-32-4-80	291116-1	X4Lxxx.HC	24	
	- 16	36°- 54°	291116-1	P4Lxxx.HC	32	2
	- 16	4-32-4-50	291116-1	Z4Lxxx.HC	32	
Q145, Q145H	- 8	60°- 30°	291116-1	H2Txxx.HA	16	1
Q155, Q155H	- 12	0°- 60°	291116-1	L2Rxxx.HA	24	6
(QUAD)	- 16	15°- 30°	291116-1	P2Bxxx.HA	32	6
	- 20	24°- 12°	291116-1	T2Bxxx.HA	40	6
V-250, V-275, W-330	- 6	36°- 84°	291116-1	F2Dxxx.HA	12	1
	- 8	36°- 54°	291116-1	H2Dxxx.HA	16	1
	- 10	36°	291116-1	J2Axxx.HA	20	2
(odd crank)	- 10	30-6-30-84-30-6-30-54-36-54	291116-1	J2Wxxx.HA	20	3
	- 12	36°- 24°	291116-1	L2Dxxx.HA	24	2
(63° crank)	- 12	36-18-36-27-36-27	291116-1	L2Vxxx.HA	24	2
(76.5° crank)	- 12	9-27-40.5-36-40.5-27	291116-1	L2Uxxx.HA	24	3
	- 16	18-18-36-18	291116-1	P2Exxx.HA	32	2
Z-330	- 12	40°- 20°	291116-1	L2Zxxx.HA	24	2
	- 16	20-20-30-20	291116-1	P2Zxxx.HA	32	2
(90° crank)	- 16	0-40-0-50	291116-1	P2Nxxx.HA	32	6
<b>DE LAVAL</b>						
HVA	- 6	120°	291116-1	F4Axxx.HC	12	1
	- 8	46°- 134°	291116-1	H40xxx.HC	16	1
	- 12	46°- 74°	291116-1	L40xxx.HC	24	2
	- 16	46°- 44°	291116-1	P40xxx.HC	32	2

## CPU-2000 DIGITAL IGNITION SYSTEM

ENGINE MODEL NO.	FIRING PATTERN	CPU-2000 OUTPUT MOD	MEMORY CODE NO.	QTY. COILS	NOTES	
<b>INGERSOLL RAND</b>						
KVG, KVGR	- 26	165°- 75°	291116-1	F4Cxxx.HC	6	
	- 36	165°- 75°	291116-1	F4Cxxx.HC	6	
	- 48	90-90-90-135-90-90-90-45	291116-1	H4Exxx.HC	8	
	- 48	90-135-45-135-90-45-135-45	291116-1	H4Kxxx.HC	8	
	- 62	165°- 75°	291116-1	F4Cxxx.HC	6	
	- 82	45°- 135°	291116-1	H4Hxxx.HC	8	
	- 83	90-90-90-135-90-90-90-45	291116-1	H4Exxx.HC	8	
	-103	117°- 27°	291116-1	J4Exxx.HC	10	
	-104	117°- 27°	291116-1	J4Exxx.HC	10	
	-123	45°- 75°	291116-1	L4Hxxx.HC	12	
	-410	117°- 27°	291116-1	J4Exxx.HC	10	
	-410	45-120-75-45-75-45-75-120-45-75	291116-1	J4Gxxx.HC	10	
	-412	45°- 75°	291116-1	L4Hxxx.HC	12	
	-510	117°- 27°	291116-1	J4Exxx.HC	10	
	-510	45-120-75-45-75-45-75-120-45-75	291116-1	J4Gxxx.HC	10	
-512	45°- 75°	291116-1	L4Hxxx.HC	12		
KVS, KVSE	- 36	165°- 75°	291116-1	F4Cxxx.HC	12	1
KVSF, KVSR	- 48	90-135-45-135-90-45-135-45	291116-1	H4Kxxx.HC	16	1
	-410	45-75-45-75-120-45-75-45-75-120	291116-1	J4Sxxx.HC	20	2
	-412	45°- 75°	291116-1	L4Hxxx.HC	24	2
	-510	45-75-45-75-120-45-75-45-75-120	291116-1	J4Sxxx.HC	20	2
	-512	45°- 75°	291116-1	L4Hxxx.HC	24	2
	-612	45°- 75°	291116-1	L4Hxxx.HC	24	2
KVT, KVR	- 38	90-90-90-135-90-90-90-45	291116-1	H4Exxx.HC	16	1
	-410	117°- 27°	291116-1	J4Exxx.HC	20	2
	-512	45°- 75°	291116-1	L4Hxxx.HC	24	2
	-616	45°	291116-1	P4Axxx.HC	32	2
PKVG, PKVGR	- 6	165°- 75°	291116-1	F4Cxxx.HC	6	
	- 8	90-90-90-135-90-90-90-45	291116-1	H4Exxx.HC	8	
	-10	117°- 27°	291116-1	J4Exxx.HC	10	
	-12	45°- 75°	291116-1	L4Hxxx.HC	12	
	-16	45°	291116-1	P4Axxx.HC	16	

INGERSOLL RAND CONTINUED ON THE NEXT PAGE



ENGINE MODEL NO.	FIRING PATTERN	CPU-2000 OUTPUT MOD	MEMORY CODE NO.	QTY. COILS	NOTES	
<b>INGERSOLL RAND</b> (continued)						
PKVS, PKVSR	- 6	165°- 75°	291116-1	F4Cxxx.HC	12	1
	- 8	90-135-45-135 90-45-135-45	291116-1	H4Kxxx.HC	16	1
	- 10	45-75-45-75-120- 45-75-45-75-120	291116-1	J4Sxxx.HC	20	2
	- 12	45°- 75°	291116-1	L4Hxxx.HC	24	2
	- 16	45°	291116-1	P4Axxx.HC	32	2
PKVT	- 12	75°- 45°	291116-1	L4Cxxx.HC	24	2
PSVG	- 6	185°- 55°	291116-1	F4Pxxx.HC	6	
	- 8	90-90-90-65- 90-90-90-115	291116-1	H4Pxxx.HC	8	
	- 10	137°- 7°	291116-1	J4Pxxx.HC	10	
	- 12	65°- 55°	291116-1	L4Pxxx.HC	12	
SVG	- 6	180°- 60°	291116-1	F4Bxxx.HC	6	
	- 8	90-90-90-60- 90-90-90-120	291116-1	H4Gxxx.HC	8	
	- 10	132°- 12°	291116-1	J4Dxxx.HC	10	
	- 12	60°	291116-1	L4Axxx.HC	12	
SVS, TVS, TVR	- 8	90-135-45-135 90-45-135-45	291116-1	H4Kxxx.HC	16	1
	- 10	117°- 27°	291116-1	J4Exxx.HC	20	2
	- 12	45°- 75°	291116-1	L4Hxxx.HC	24	2
<b>M.E.P.</b>						
M.E.P.	- 6	60°	291116-1	F2A318.HC	12	1, 4
	- 8	45°	291116-1	H2A318.HC	16	1, 4
	- 10	36°	291116-1	J2A318.HC	20	2, 4
	- 12	30°	291116-1	L2A318.HC	24	3, 4
<b>NORDBERG</b>						
FSE	- 6	120°	291116-1	F4Axxx.HC	12	1
	- 1316	45°	291116-1	P4Axxx.HC	32	2
<b>RUSTON</b>						
RK270G	- 12	75°- 45°	291116-1	L4C292.HC	24	2, 4
	- 16	45°	291116-1	P4A292.HC	32	2, 4
<b>SUPERIOR</b>						
825 Series G, GT	- 6	120°	291116-1	F4A230.HC	6	4
	- 8	90°	291116-1	H4A230.HC	8	4
	- 12	48°- 72°	291116-1	L4D276.HC	12	4, 5
	- 16	48°- 72°	291116-1	P4G276.HC	16	4, 5
GTL	- 6	120°	291116-1	F4A230.HC	6	4
	- 8	90°	291116-1	H4A230.HC	8	4
	- 12	48°- 72°	291116-1	L4D276.HC	12	4, 5
	- 16	48°- 72°	291116-1	P4G276.HC	16	4, 5

SUPERIOR CONTINUED ON THE NEXT PAGE

## CPU-2000 DIGITAL IGNITION SYSTEM

ENGINE MODEL NO.		FIRING PATTERN	CPU-2000 OUTPUT MOD	MEMORY CODE NO.	QTY. COILS	NOTES
<b>SUPERIOR (continued)</b>						
GTLA, GTLB	- 6	120°	291116-1	F4A230.HC	6	4
	- 8	90°	291116-1	H4A230.HC	8	4
	- 12	48°- 72°	291116-1	L4D276.HC	12	4
	- 16	48°- 42°	291116-1	P4G276.HC	16	4
SGT	- 12	48°- 72°	291116-1	L4D276.HC	12	4, 5
	- 16	48°- 42°	291116-1	P4G276.HC	16	4, 5
SGTA, SGTB	- 8	90°	291116-1	H4A230.HC	8	4
	- 12	48°- 72°	291116-1	L4D276.HC	12	4
	- 16	48°- 42°	291116-1	P4G276.HC	16	4
2400 Series	2406G	120°	291116-1	F4A180.HC	6	4
	2408G	90°	291116-1	H4A180.HC	8	4
	2412G	60°	291116-1	L4A180.HC	12	4
	2416G	60°- 30°	291116-1	P4T180.HC	16	4
<b>WORTHINGTON</b>						
LTC	- 3	120°	291116-1	G2Axxx.HA	6	1
	- 4	90°	291116-1	D2Axxx.HA	8	1
	- 5	72°	291116-1	E2Axxx.HA	10	1
	- 6	60°	291116-1	F2Axxx.HA	12	1
	- 8	45°	291116-1	H2Axxx.HA	16	1
ML (MAINLINER)	- 5	72°	291116-1	E2Axxx.HA	10	1
	- 6	60°	291116-1	F2Axxx.HA	12	1
	- 7	51.43°	291116-1	G2Axxx.HA	14	1
	- 8	45°	291116-1	H2Axxx.HA	16	1
	- 10	36°	291116-1	J2Axxx.HA	20	2
MLV (MAINLINER)	- 10	36°	291116-1	J2Axxx.HA	20	2
	- 12	36°- 24°	291116-1	L2Dxxx.HA	24	2
	- 14	36°- 15.43°	291116-1	N2Dxxx.HA	28	3
	- 16	36°- 9°	291116-1	P2Dxxx.HA	32	3
	- 18	36°- 4°	291116-1	R2Dxxx.HA	36	6
	- 20	0°- 36°	291116-1	T2Rxxx.HA	40	6
SLHC	- 4	180-90-180-270	291116-1	D4Sxxx.HC	8	1
	- 5	144°	291116-1	E4Axxx.HC	10	1
	- 6	120°	291116-1	F4Axxx.HC	12	1
	- 7	102.86°	291116-1	G4Axxx.HC	14	1
	- 8	90°	291116-1	H4Axxx.HC	16	1
	- 10	72°	291116-1	J4Axxx.HC	20	2

WORTHINGTON CONTINUED ON THE NEXT PAGE

ENGINE MODEL NO.	FIRING PATTERN	CPU-2000 OUTPUT MOD	MEMORY CODE NO.	QTY. COILS	NOTES	
<b>WORTHINGTON (continued)</b>						
UTC, SUTC	- 5	72°	291116-1	E2Axxx.HA	10	1
	- 6	60°	291116-1	F2Axxx.HA	12	1
	- 7	51.43°	291116-1	G2Axxx.HA	14	1
	- 8	45°	291116-1	H2Axxx.HA	16	1
	- 8	0°- 90°	291116-1	H2Rxxx.HA	16	6
	- 10	36°	291116-1	J2Axxx.HA	20	2

**APPLICATION NOTES:**

- 1 If using the optional Diagnostic Module, optimum results are obtained with each ignition coil connected to a separate primary output. To provide this for the application listed where two ignition coils are used per cylinder, specify memory code "6" or "8" (see page 1).
- 2 If using the optional Diagnostic Module, optimum results are obtained with each ignition coil connected to a separate primary output. To provide this for the application listed where two ignition coils are used per cylinder, use Output Module 291132-1 and memory code "6" or "8" (see page 1).
- 3 If using the optional Diagnostic Module, optimum results are obtained with each ignition coil connected to a separate primary output. To provide this for the application listed where two ignition coils are used per cylinder, use Output Module 291132-2 and memory code "6" or "8" (see page 1). NOTE: The multi-strike feature is not available with Output Module 291132-2.
- 4 Memory code listed is for standard engine ring gear. If a different number of teeth/holes are to be sensed, the memory code no. must be changed accordingly.
- 5 Alternate ring gear has 249 teeth; check number to verify correct memory code no.
- 6 This application is not available with two outputs for each cylinder (memory code 6 or 8).