

ALTRONIC, INC.
712 TRUMBULL AVE.
GIRARD, OHIO 44420

**ALTRONIC III-CPU IGNITION SYSTEMS
"C" VERSION**

IMPORTANT SAFETY NOTICE

PROPER INSTALLATION, MAINTENANCE, REPAIR AND OPERATION OF THIS EQUIPMENT IS ESSENTIAL. THE RECOMMENDED PRACTICES CONTAINED HEREIN SHOULD BE FOLLOWED WITHOUT DEVIATION. AN IMPROPERLY INSTALLED OR OPERATING IGNITION SYSTEM COULD CAUSE PERSONAL INJURY TO OPERATORS OR OTHER NEARBY PERSONNEL.

TABLE OF CONTENTS**ALTRONIC III-CPU SERVICE INSTRUCTIONS**

| SECTION | ITEM | PAGE |
|----------------|--|-------------|
| 1.0 | SYSTEM DESCRIPTION | 3 |
| 2.0 | PARTS IDENTIFICATION AND SPECIFICATION | 5 |
| 2.1 | Parts List - III-CPU Unit | 5 |
| 3.0 | TEST STAND REQUIREMENTS | 6 |
| 4.0 | TESTING PROCEDURE - III-CPU UNIT | 7 |
| 4.1 | Operational Test | 7 |
| 5.0 | OSCILLOSCOPE TESTING | 7 |
| 5.1 | Test Set-up | 7 |
| 5.2 | Storage Capacitor Voltage Pattern | 7 |
| 6.0 | TROUBLESHOOTING | 8 |
| 7.0 | LOGIC BOARD REPLACEMENT PROCEDURE | 8 |
| 7.1 | Disassembly Procedure | 8 |
| 7.2 | Assembly Procedure | 8 |

1.0 ALTRONIC III-CPU - SYSTEM DESCRIPTION

The Altronic III-CPU ignition system is a microcircuit-based, capacitor discharge system. Referring to the diagram below, the system retains a standard Altronic III unit which provides the power for the basic operation of the CPU Control Unit and performs the distribution function. The system also uses two signals from external magnetic pick-ups: (1) counts from a crankshaft-mounted gear (ring gear) or drilled holes in the engine flywheel; (2) a reset pulse once per revolution.

The III-CPU Unit consists of a microcircuit logic board with a memory chip. The memory chip is programmed with the engine firing angle sequence and the number of reference teeth. The logic board outputs precisely timed trigger pulses to the Altronic III unit which routes the stored primary energy to the ignition coils in sequence.

The Altronic III-CPU system implements timing changes by counting pulses from the reference teeth or holes. The timing change increment is equal to $360/2N$ where N = the number of reference teeth or holes. With 180 teeth as recommended for test purposes, the timing change increment is one degree.

Three ways are provided to vary ignition timing:

- Manual timing adjustment with SW1, an internal 10-position switch;
- Step-change timing adjustment set with SW2, a 16-position switch;
- Control from an external 4-20 ma current loop signal.

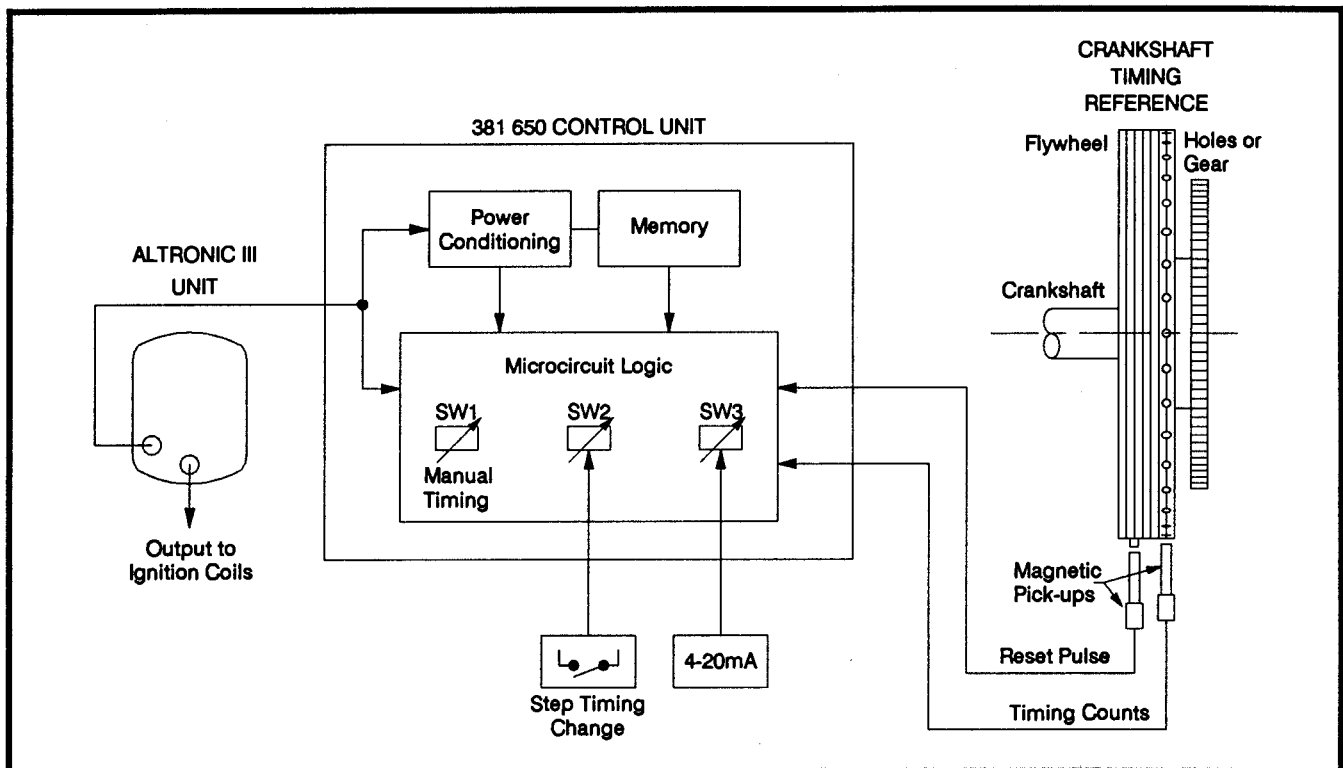

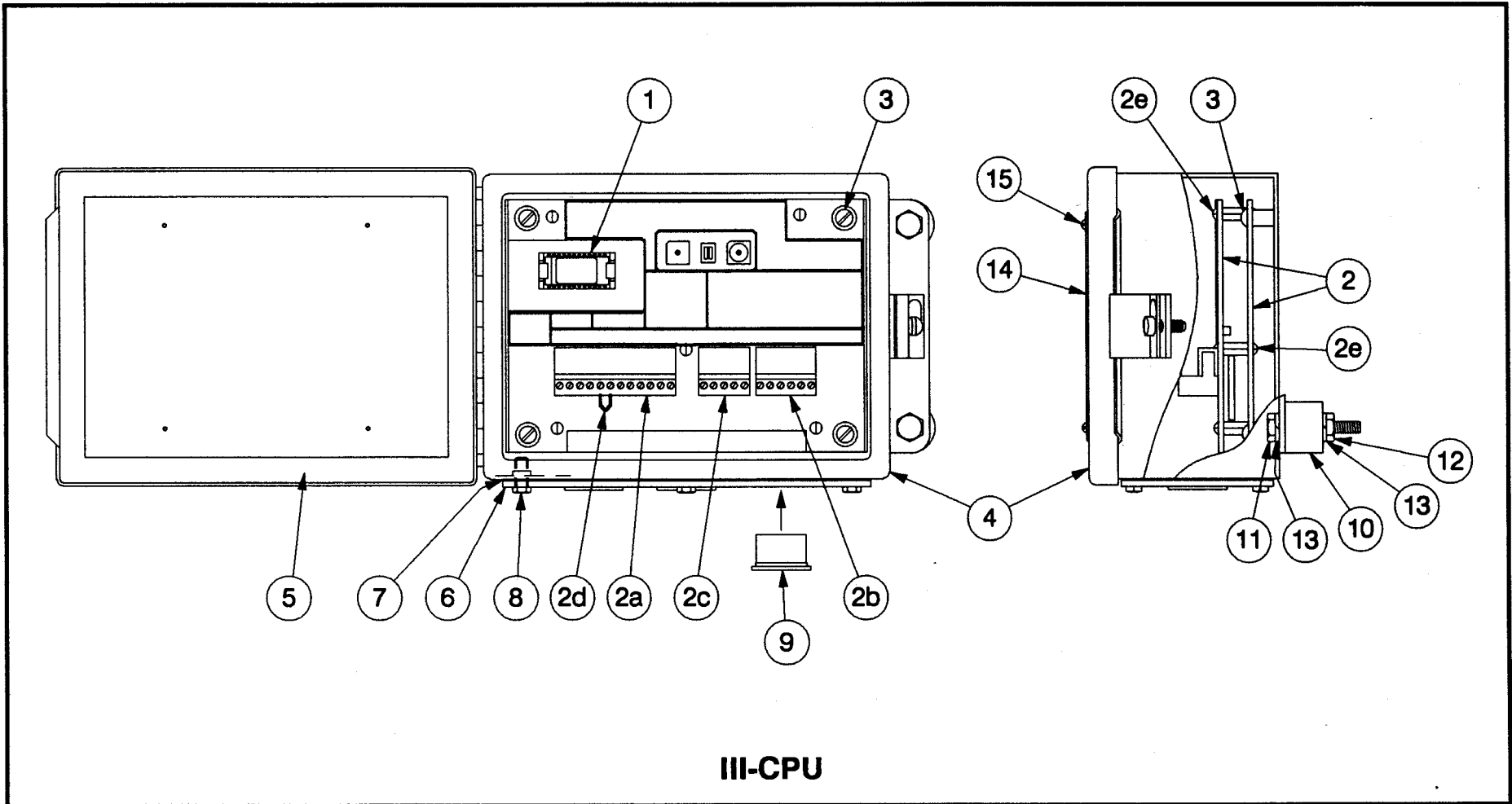

2.0 PARTS IDENTIFICATION AND SPECIFICATION

2.1 PARTS LIST - III-CPU UNIT: 381 650-1

| FIGURE & REF. NO. | QTY. | PART NO. | DESCRIPTION |
|----------------------------------|-------------|-----------------|----------------------------|
| 1 | 1 | 601 275 | Memory chip |
| | | 601 275-S | Memory chip - non-standard |
| 2 | 1 | 374 001 | Logic board assembly |
| 2a | 1 | 204 014 | Socket - 12-pin |
| 2b | 1 | 204 015 | Socket - 6-pin |
| 2c | 1 | 204 016 | Socket - 5-pin |
| 2d | 1 | 503 242 | Lead - jumper |
| 2e | 10 | 902 064 | Screw - 6-32 |
| 3 | 4 | 902 439 | Screw - 10-32 |
| 4 | 1 | 310 579 | Enclosure |
| 5 | 1 | 610 516 | Gasket - cover |
| 6 | 1 | 210 622 | Plate - entry |
| 7 | 1 | 210 625 | Gasket - plate |
| 8 | 6 | 902 599 | Screw 10-24 |
| 9 | 3 | 510 540 | Cap |
| 10 | 4 | 610 165 | Shock mount |
| 11 | 4 | 902 593 | Bolt 5/16-18 |
| 12 | 4 | 902 469 | Nut 5/16-18 |
| 13 | 8 | 901 010 | Lockwasher 5/16 |
| 14 | 1 | 302 120A | Nameplate |
| 15 | 4 | 902 578 | Screw 4-40 |

3.0 TEST STAND REQUIREMENTS

- 3.1 In order to test an Altronic III-CPU ignition system, a specialized test stand is required. Such a stand can be built starting with the elements of an ignition test stand suitable for a standard Altronic III system.
- 3.2 A standard ignition test stand includes these items:
- A. A variable speed motor of 0.5 HP or greater, capable of rotating 1,800 RPM.
 - B. Mounting adaptation to base or flange mount configuration.
 - C. A spark degree wheel graduated in 360 increments with the indicator attached to the shaft driving the Altronic III unit.
 - D. Sixteen (16) ignition coils 501 061 connected to suitable, adjustable spark gaps.
- 3.3 The following items are additionally required to test the Altronic III-CPU system.
- A. A source of gear tooth pulses mechanically connected to the motor drive; a 180 tooth gear is suggested.
 - B. A single reset pin (6-32 machine screw suggested) mounted to the face of the gear.
 - C. Magnetic pick-ups mounted to sense the gear teeth (A.) and reset pin (B.).
 - D. A 581 602 manual control loop unit to simulate the 4-20ma control signal.
 - E. A DC power source capable of supplying 12-24VDC, 5 amps.
 - F. An Altronic III unit; model 12A35 is suggested. NOTE: The Altronic III unit must be properly synchronized to the test stand. Determine the test stand position when the reset pin lines up directly opposite the reset pick-up; then time the Altronic III unit (using shorting plug 593 045 or with CPU switch SW3-A in the CLOSED position) so that the "A" output fires 7-8 degrees more advanced than the reset line-up position.
 - G. A 12-cylinder test memory chip programmed with the number of teeth used on the test stand (usually 180). Example: L4A180.CD.

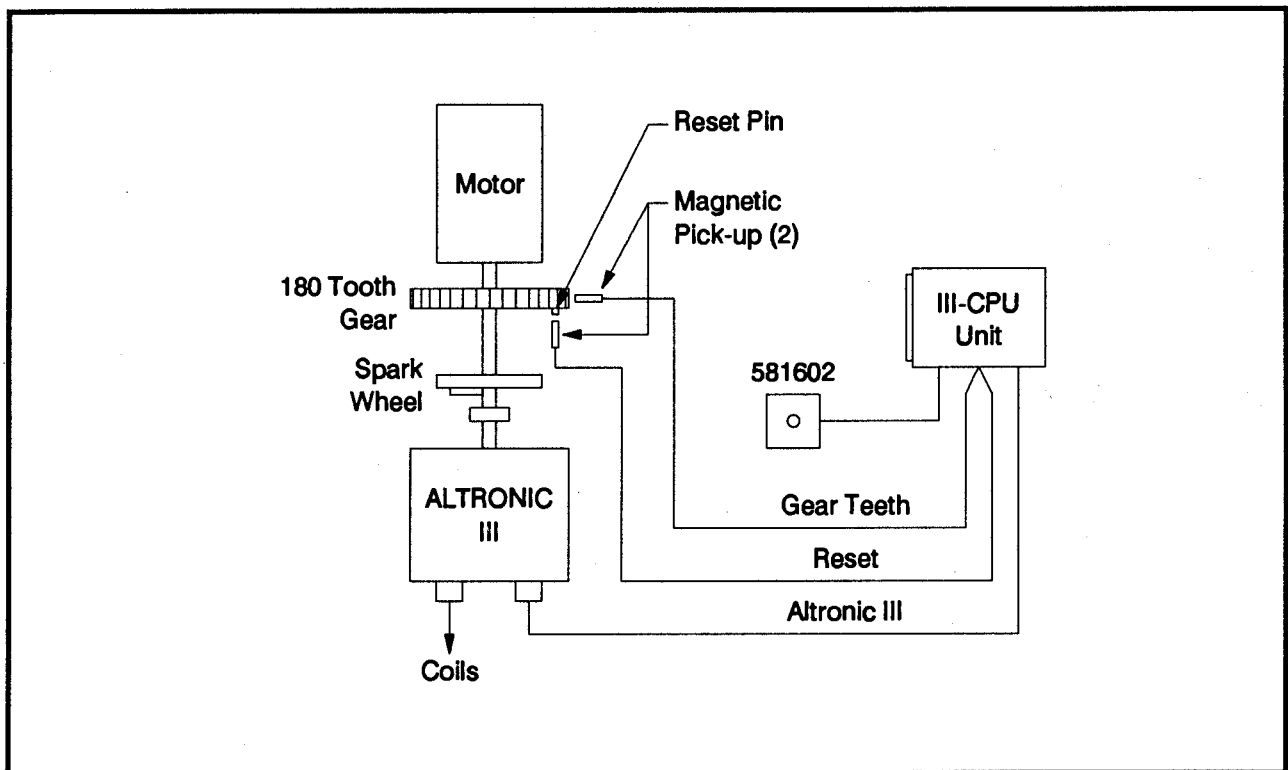

4.0 TESTING PROCEDURE - III-CPU UNIT: 381 650-1

4.1 OPERATIONAL TEST - With the system completely connected, operate the test stand (180-tooth gear) at the speed indicated for each step. NOTE: Switch SW-3A should be in the OPEN position.

| 180 TOOTH GEAR RPM | TEST |
|--------------------|---|
| 90 RPM | All outputs fire a 7mm gap. |
| 600 RPM | All outputs fire a 15mm gap. |
| 1500 RPM | Each cylinder fires consistently in sequence; timing as follows starting with output "A" and proceeding in alphabetical sequence A-B-C-D-E-F-H-I-J-K-L-M. Memory chip L4A180.CD: 0-60-120-180-240-300-0-60-120-180-240-300 |
| 150-600 RPM | Timing change on output lead "A". Timing should retard in one jump as speed is increased from 150 to 600 RPM as the system switches from manual override to electronic mode. |
| 1500 RPM | Timing change on output lead "A". Timing switch SW1: 1 degree per switch step = 9 degrees total span Timing switch SW2: 1 degree per switch step = 15 degrees total span Analog input timing control (SW3-B in OPEN position): 16 degrees change from 4-20 ma (1-5V.) input |

5.0 OSCILLOSCOPE TESTING

5.1 TEST SET-UP - Two 100:1 oscilloscope probes are required. NOTE: The signals being monitored are 150 volts, positive polarity. The system should be completely connected and the Altronic III unit (12A35) operating at the speed indicated below.

5.2 STORAGE CAPACITOR VOLTAGE PATTERN

- A. The trigger input of the oscilloscope should be connected to the "A" primary coil lead. NOTE: This is a 150 volt, positive polarity signal.
- B. Connect the oscilloscope probe to the "G" lead of the output connector. See the waveform below for a 12A35 unit. The waveform should be basically the same with the CPU Control Unit connected as with the standard Altronic III system.

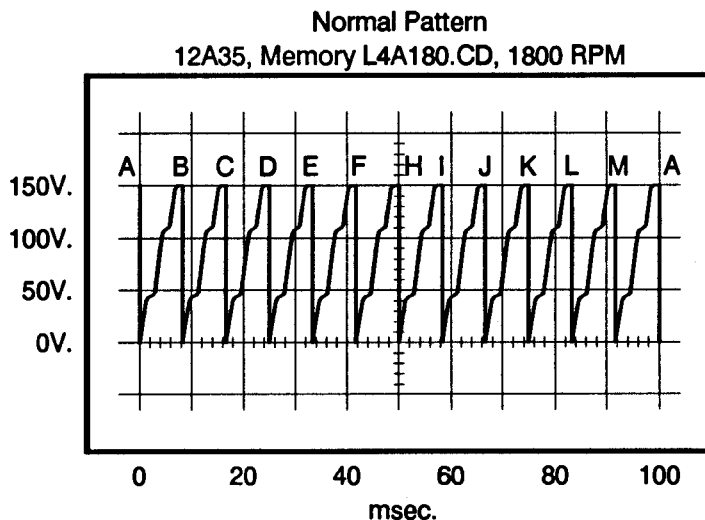

6.0 TROUBLESHOOTING

Perform all tests with the test stand operating at the speed indicated in the referenced test. The following chart assumes a properly functioning Altronic III unit and properly installed magnetic pick-ups.

| PROBLEM | TEST | TEST INDICATION | CORRECTIVE ACTION |
|------------------------|-------------------|---|--|
| Misfiring or no output | Section 4.1 / 5.2 | Missing discharge on test stand or oscilloscope | Check proper synchronization of Altronic III unit with reset pin position (see 3.3F.) If above is OK, change logic board ass'y. (2) |
| Timing varies | Section 4.1 | Timing other than as shown | Make sure switch SW3-A is in OPEN position. If above is OK, change logic board ass'y. (2) |

7.0 LOGIC BOARD REPLACEMENT PROCEDURE

7.1 DISASSEMBLY PROCEDURE

- A. Loosen and remove four screws (3). Lift the logic board assembly (2) out of the box. This consists of two circuit boards connected by a ribbon cable; these are replaced as a unit.

7.2 ASSEMBLY PROCEDURE

- A. Check the condition of the gaskets (5) and (7) and the shock mounts (10); replace if necessary. Install new hardware where needed.
- B. Be sure the ten screws (2e) holding the two circuit boards together are tight. Then set the logic board assembly (2) into place in the box. Install and tighten four screws (3).
- C. Retest the completely assembled unit per sections 4.0 and 5.0 to insure correct operation.