

ALTRONIC®, INC.
712 TRUMBULL AVENUE
GIRARD, OHIO 44420

ALTRONIC II-CPU IGNITION SYSTEM
ALTERNATOR POWERED, "D" SERIES

INSTALLATION INSTRUCTIONS
FORM AII-CPU II 6-88

WARNING: AN IMPROPERLY INSTALLED OR OPERATING IGNITION SYSTEM MAY LEAD TO IMPROPER ENGINE OPERATION WHICH CONSEQUENTLY COULD POSE THE THREAT OF PERSONAL INJURY TO OPERATORS OR OTHER NEARBY PERSONNEL.

1.0 DESCRIPTION

- 1.1 The Altronic II-CPU ignition system is a microcircuit-based, self-powered capacitor discharge system applicable to slow speed, high BMEP engines. The system features crankshaft-triggered timing accuracy and the capability to vary timing electronically by several means, including an external 4-20 ma. control signal. The Altronic II-CPU system consists of an alternator unit, a CPU control unit, (2) magnetic pick-ups and cables, (2) wiring harnesses and an ignition coil for each spark plug; see drawing 209 101 for a total system overview. In most applications, the Altronic II-CPU unit provides adequate starting output at an engine speed of 35-50 RPM.
- 1.2 For non-hazardous operations there is an unshielded epoxy coil 291 001. For hazardous area operations, shielded primary cable assemblies are available for connection to one of two optional shielded coil series - 291 001-S or 591 008. NOTE: Use only the above Altronic coils with the Altronic II-CPU ignition system.

2.0 MOUNTING THE ALTRONIC II-CPU ALTERNATOR UNIT

- 2.1 Set the engine with No. 1 cylinder six (6) degrees ahead of the most advanced desired firing position.
- 2.2 The flex coupling (560 002, 560 003 or 560 009) should be attached to the unit shaft with a spring pin. Attach the engine drive member (560 001 or 560 008) to the end of the coupling using the two spring pins provided. Flange mount units may use lug-type coupling 510 454-P in which case the engine drive member referred to above is not used.
NOTE: For the safety of operating personnel, the engine manufacturer's shield must be in place covering the flex coupling/engine drive.
- 2.3 Turn the alternator drive shaft until a 1/4" rod can engage the hole in the drive shaft through the hole near the coupling end of the unit. On 4-cycle engines only, remove the back cover from alternator unit; the distributor shaft assembly 280 601-X must be installed so that the red marks on the mating gears line-up. The alternator unit is now set to fire no. 1 cylinder.
- 2.4 Install the alternator unit on the engine bracket. Slip engine drive member 560 001 or 560 008 over the existing drive hub (or new hub 510 551); insert and tighten locking screw and locknut. Flex couplings 560 002 and 560 003 should not be stretched or compressed; with the gear flex coupling 560 009 or lug-type coupling 510 454-P, allow .015" clearance for the floating member on each side. Secure the alternator unit to the engine bracket with 3/8"-16 screws maintaining proper alignment.

3.0 MOUNTING THE ALTRONIC II-CPU CONTROL UNIT

- 3.1 Select a mounting location meeting the following requirements (refer to drawing 209 101):
- Located within 60 inches of the alternator unit.
 - Located within 84 inches of the primary junction box.
 - The front panel door of the control unit should be easily accessible and free to swing open.
 - Avoid locations with an ambient temperature higher than 150°F. (65°C.).
- 3.2 The control box should be fastened securely to a rigid engine bracket using the shock mounts provided.
- 3.3 Connect harness 293 024 to the alternator unit and secure it such that it is kept away from sources of high temperature or mechanical damage.

4.0 MOUNTING FLYWHEEL GEAR / DRILLING FLYWHEEL HOLES

- 4.1 The Altronic II-CPU system requires a source of angular position pulses from the engine crankshaft. This can be a flywheel ring gear, a separately provided gear or specially drilled holes in the flywheel. The source of position pulses must meet the following requirements:
- Must be ferrous material
 - Diameter of 18" or greater
 - No. of teeth or holes of 180 or greater
 - Maximum runout referenced to the pick-up of .007"
- Refer to drawings 209 101, 209 102 and 209 103 for further details.

5.0 MOUNTING THE MAGNETIC PICK-UPS

- 5.1 The system requires two magnetic pick-up signals: the angular position pulses from the gear or drilled holes and a reset pulse near the most advanced firing position desired for no. 1 cylinder. The pick-ups must be mounted to rigid brackets to maintain an air gap of $.015" \pm .005"$ with respect to the rotating gear or flywheel. It is also important for maximum signal efficiency that the centerline of the pick-up pass through the center of the rotating part
- see drawing 209 102.

6.0 MOUNTING THE FLYWHEEL RESET PIN

- 6.1 Set the engine with no. 1 cylinder six (6) degrees ahead of the most advanced firing point. Mark a point on the flywheel directly opposite the pole piece of the reset magnetic pick-up; then rotate the engine to a position convenient for drilling and tapping the flywheel at the point marked above. The reset pin should be made from a steel (magnetic) 1/4"-20 bolt or stud. See drawing 209 102 for details.
- 6.2 Rotate the engine to the original set point and adjust the air gap between the end of the reset pin and the magnetic pick-up at .010" using a feeler gauge.

7.0 CPU CONTROL UNIT WIRING

- 7.1 RIGHT-HAND ENTRY - Attach the open end of harness 293 024 from the Altronic II alternator to the right-hand entry in the bottom access plate of the CPU unit using the nut provided. Refer to drawing 509 025 if it is desired to shorten the conduit length of the harness. Terminate the wires as shown on drawing 209 104A.
- 7.2 CENTER ENTRY - Run a separate conduit for the two (2) magnetic pick-up cable assemblies. These should enter through the center entry in the CPU box and terminate as shown on drawing 209 104A. The entry hole is sized for a 1/2"-14 NPT male conduit fitting.
- 7.3 LEFT-HAND ENTRY - A separate conduit must be used to the left-hand entry for all connections to the left-hand, 12-position terminal strip in the CPU box. Use 24AWG, UL style 1015 wire for all these connections; this wire is available from Altronic under part no. 603 102 (black) or 603 103 (white).
- A. Terminals 1-4 are used for the 4-20 ma timing control connections. The 4-20 ma loop connects to terminals 1 and 2; the 12-24 VDC supply voltage is connected to terminals 3 and 4. See drawings 209 104A and 209 110. NOTE: Terminals 2 and 4 MUST BE common negative supply.
- B. Terminals 5 and 6 are used for the one-step timing adjustment if used; see drawings 209 104A and 209 109.
- C. If used, the fault output leads connect to terminals 10 and 11; see drawing 209 111 and section 12.2 for details.

8.0 PRIMARY WIRING (REFER TO WIRING DIAGRAMS 209 105/209 106)

- 8.1 The main wiring harness (293 023-X, 293 026-X, or 293 027-X) connects the CPU control unit to the engine junction box. Refer to drawing 509 025 if it is desired to shorten the conduit length of the harness. Insert the connector into the Altronic II-CPU control unit and tighten hand tight; then carefully tighten an additional one-sixth turn with a wrench.
- 8.2 Write in the engine firing order below the applicable CPU control unit:
- | | |
|-----------|---|
| 281 508-X | A - B - C - D - E - F - G - H |
| ENGINE: | _____ |
| 281 512-X | A - B - C - D - E - F - G - H - J - K - L - M |
| ENGINE: | _____ |
| 281 516-X | A - B - C - D - E - F - G - H - J - K - L - M - R - S - T - U |
| ENGINE: | _____ |
| 281 520-X | A1-A2-B1-B2-C1-C2-D1-D2-E1-E2-F1-F2-G1-G2-H1-H2-J1-J2-K1-K2 |
| ENGINE: | _____ |
- 8.3 Connect the harness leads in the junction box in accordance with the engine's firing order. The leads from the junction box corresponding to the above system outputs connect to the ignition coil negative (-) terminals. The "P" lead and the common coil ground lead(s) connecting the positive (+) terminals of the ignition coils must be grounded to the engine in the junction box. On V-engines, run a separate common ground lead for each bank. All primary wiring should be protected from physical damage and vibration. Refer to wiring diagrams 209 105 (unshielded) or 209 106 (shielded) for general details.

8.4 Primary wire should be no. 16 gauge stranded, tinned copper wire. The insulation should have a minimum thickness of .016" and be rated 105°C. or higher. Irradiated PVC or polyolefin insulations are recommended. Altronic primary wire no. 503 188 meets these specifications.

8.5 If two ignition coils per cylinder connected to a common output are used, use parallel wiring as shown on the wiring diagrams 209 105 and 209 106.

9.0 "N" AND "V" LEAD - SAFETY SWITCH WIRING

9.1 Either the "N" or "V" lead must be used as the safety shutdown wire which will stop the ignition when grounded.

- The "N" lead directly shorts the storage capacitors. If grounded during the start-up sequence, there will be an approximate 5 second delay after ungrounding before ignition commences. (There is no delay when grounding for shutdown.) The start-up delay may be eliminated or minimized by using the "V" lead instead of the "N" lead.

- The "V" lead shorts the storage capacitors through a circuit which allows the logic portion of the CPU control unit to function while preventing sufficient output to the coils for ignition to occur. If the "V" lead is kept grounded for 5 seconds or more after the engine begins cranking, ignition will commence as soon as the "V" lead is ungrounded.

DO NOT connect leads "N" and "V" together at any time.

9.2 To minimize arcing at the switch(es) connected to the shutdown lead, use a 100 ohm, 1 watt resistor in series with the "N" or "V" lead, whichever is used.

9.3 Safety switches and associated wiring must be in top condition for proper operation with the Altronic II-CPU system. Partial shorts or leakage in this wiring can prevent the system from operating properly. It is recommended that safety switches and associated wiring be checked with a megger before installing the Altronic II-CPU system. There should be no indication of leakage to ground.

9.4 If the above wiring and/or switches are the problem, the usual result is one of the following:

- engine will start but stops when safety shutdown devices are switched into the circuit;
- engine will start but will not carry load

9.5 If ignition output is thought to be weak, the first step should be to disconnect the safety switch wiring completely. This will show whether the problem is in this area. If so, the individual switches and wires must be checked out to find the source of the leak to ground.

10.0 SECONDARY WIRING

10.1 Mount the ignition coils as close as possible to the engine spark plugs consistent with a secure mounting and avoidance of temperatures in excess of 185°F.

10.2 The spark plug leads should be fabricated from 7mm, silicone insulated, tinned copper conductor with suitable terminals and silicone spark plug boot. Keep spark plug leads as short as possible and in all cases not longer than 18 inches. Spark plug leads should be kept at least 2 inches away from any grounded engine part. In deep spark plug wells, use rigid, insulated extenders projecting out of the well.

10.3 The use of a clear, silicone grease (such as Dow Corning DC-200) is recommended for all high-tension connections and boots. This material helps seal out moisture and prevent corrosion from atmospheric sources.

11.0 OPERATION (Refer to drawing 209 107)

11.1 The Alternator Assembly provides the power for the basic system operation. A transistor-zener voltage regulator determines the voltage on the energy storage capacitors. On 4-cycle engines, a Hall-effect cycle trigger is used to determine whether the flywheel is on the compression or exhaust stroke. The gearing in the alternator is such that the distributor magnet rotates at one-half engine speed thus triggering the Hall-effect switch once every two engine revolutions. On 2-cycle engines, the gears and distributor magnet are not required.

11.2 The CPU Control Unit consists of power conditioning circuitry for the logic circuit and memory, and an electronic distribution circuit. The system operates with two magnetic pick-up inputs. One counts the teeth on a crankshaft-mounted gear or holes drilled in the flywheel; the other provides a reset pulse once per engine revolution. Two counts are provided for each gear tooth or flywheel hole. Thus the degree separation from one count to the next is $360/2N$, where N = no. of teeth or holes. This value is called a TOOTH DEGREE.

Examples: No. of teeth = 180
TOOTH DEGREE = $360/2 \times 180 = 1.0$ engine degree
No. of teeth = 230
TOOTH DEGREE = $360/2 \times 230 = 0.78$ engine degree

The TOOTH DEGREE is the basic unit of timing adjustability or change in the system. As ignition timing is varied on an operating engine, it will vary one TOOTH DEGREE at a time; no finer increment is possible. Therefore, a minimum of 180 interruptions (teeth or holes) is recommended.

The system's logic circuit and memory work together to output the proper firing sequence for a given engine application. The degree separation in tooth degrees is stored in the memory. The position of the reset magnetic pick-up (degrees BTDC) determines the maximum advanced timing point for the system.

11.3 All timing adjustments are made by delaying (retarding) the spark output a given number of TOOTH DEGREES. There are three ways to vary ignition timing with the Altronic II-CPU system; all are through connections and/or switches in the CPU control unit (refer to drawing 209 108A):

- MANUAL SETTING (SW1) - This subtracts TOOTH DEGREES (0-15) from the reset pin position to determine the maximum advance timing point in operation.
- ONE-STEP SETTING (SW2) - This sets another retard amount in TOOTH DEGREES (0-15) that can be switched-in through the use of external contacts (see drawing 209 109).
- 4-20 MA ADJUSTMENT (SW3) - Open position allows influence of the 4-20 ma. control loop signal; closed position deletes any effect from the loop signal. The system reads "4 ma." as no retard, "20 ma." as full retard and is linear in between. The standard ranges of the system are 24 engine degrees (code C), 36 engine degrees (code B) and 48 engine degrees (code A); the timing range code letter is the last letter in the Memory Code Part No. - see section 11.4. Drawing 209 110 shows the timing curve vs. milliamp (ma.) signal input and the wiring hook-up.

11.4 The system memory chip contains the specific information for any particular engine application. This includes no. of cylinders, 2 or 4-cycle, engine firing pattern in degrees, no. of teeth or holes being sensed, and timing range on 4-20 ma. loop control. The Memory Code Part No. is written on the large memory integrated circuit chip in the CPU Control Unit. See form AII-CPU AL for the Memory Code Part No. to be sure the system program meets the application requirements. To order a spare memory chip, order part no. 601 507 (memory code).

12.0 INDICATION OF CURRENT LOOP OPERATION

12.1 The logic board on the cover of the CPU Control Unit has a LED indicator light for current loop operation. The light should be on if the system is on current loop operation; if not, check connections 1 through 4 and the external loop circuits.

12.2 The system also has a normally-closed, solid state fault-output switch available at terminals 10 and 11 in the CPU control unit; this automatically opens if the 4-20 ma control loop or the loop power supply is lost. The internal switch has a rating of 30 VDC, 250 ma. Terminals 10 and 11 in the CPU control unit may be connected to an external alarm or shutdown device; a typical hook-up using a relay is shown on drawing 209 111.

NOTE: Terminal 11 must be the negative supply; it is electrically common with terminals 2 and 4 - see drawing 209 111.

13.0 TROUBLESHOOTING GUIDE

PROBLEM	TEST PROCEDURE	TEST RESULT	CORRECTIVE ACTION
Ignition not firing on any cylinder.	Measure voltage at CPU unit "N" pin.	Below 30 VDC	See checklist #1
		30-150 VDC	Check cranking RPM
		Above 150 VDC	See checklist #2
Ignition mis-firing on one cylinder only	Check primary with oscilloscope or timing light	Primary firing	Check spark plug, coil or plug lead.
		No primary firing	See checklist #3
Ignition timing steady but incorrect	Check timing on several cylinders on each bank	All incorrect by same amount	See checklist #4
		Incorrect by varying amounts	See checklist #5
Ignition timing varies	Put SW3 in closed position	Timing OK	4-20 ma signal is problem
		Timing still varies	Check gap and alignment of gear-tooth (or hole) pick-up

Checklist #1

1. Disconnect shutdown wires from leads "N" or "V"; if voltage is now OK, problem is in shutdown system.
2. If voltage is still low with shutdown lead disconnected, disconnect the primary harness. If voltage is now OK, problem is the CPU control unit (distributor board).
3. If voltage is still low with harness disconnected, unplug the 5-pin connector from the alternator back cover. Measure voltage at alternator 5-pin connector: (+) to "A" pin, (-) to "B" pin; if voltage OK, problem is the CPU control unit (distributor board). If voltage still low, problem is in the alternator unit.

Checklist #2

1. Check primary ground connections and coil grounds.
2. Check air gap (.015") and alignment vs. interrupting element on both magnetic pick-ups.
3. Check continuity of magnetic pick-up connections. Unplug the 5-position plug (middle) inside the CPU control unit. Measure resistance across the two pairs of magnetic pick-up leads; 1,100 ohms is the correct reading.
4. Check the distributor shaft gear alignment on 4-cycle engines. The magnet must be over the small Hall-effect switch when the reset pin lines up with the reset magnetic pick-up on the compression stroke of no. 1 cylinder.
5. If all above checks are OK and system still does not fire, problem is in the CPU control unit.

Checklist #3

1. Check all primary wiring and connections for continuity and/or shorts to ground.
NOTE: Do not apply a megger or other high voltage tester without first disconnecting the main harness from the CPU control unit.
2. If above appears OK, problem is most likely in CPU control unit (distributor board).

Checklist #4

1. Attempt to remedy by changing position of manual timing switch SW1 - see drawing 209 108A.
2. If timing still is incorrect, check for proper position of reset pin; see section 6.0.

Checklist #5

1. Check firing order of engine vs. CPU firing order (A-B-C-etc.).
2. Check memory code no. vs. application - see section 11.4.

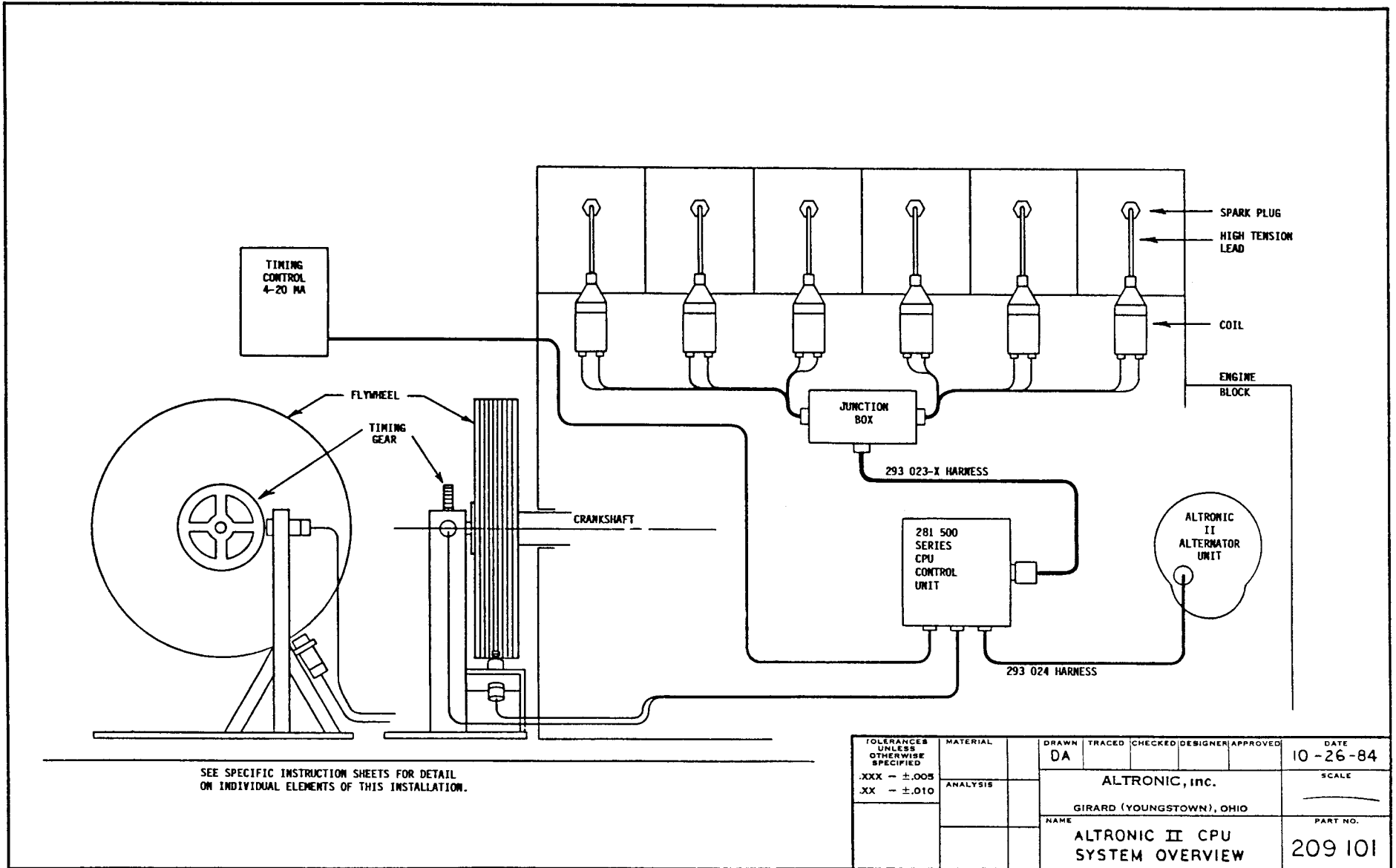

TOLERANCES UNLESS OTHERWISE SPECIFIED .XXX - ±.005 .XX - ±.010	MATERIAL ANALYSIS	DRAWN	TRACED	CHECKED	DESIGNER	APPROVED	DATE
		DA					10-26-84
		ALTRONIC, inc.					
GIRARD (YOUNGSTOWN), OHIO							PART NO.
NAME ALTRONIC II CPU SYSTEM OVERVIEW							209 101

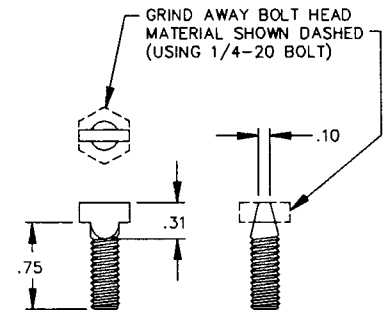
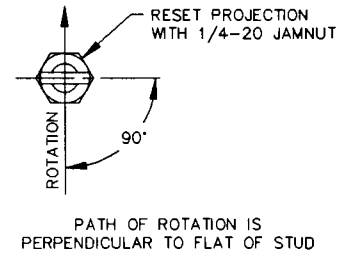
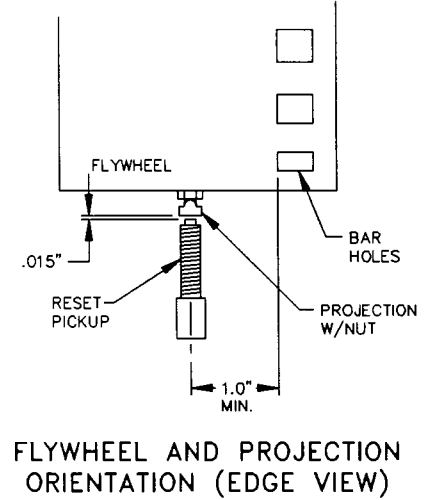
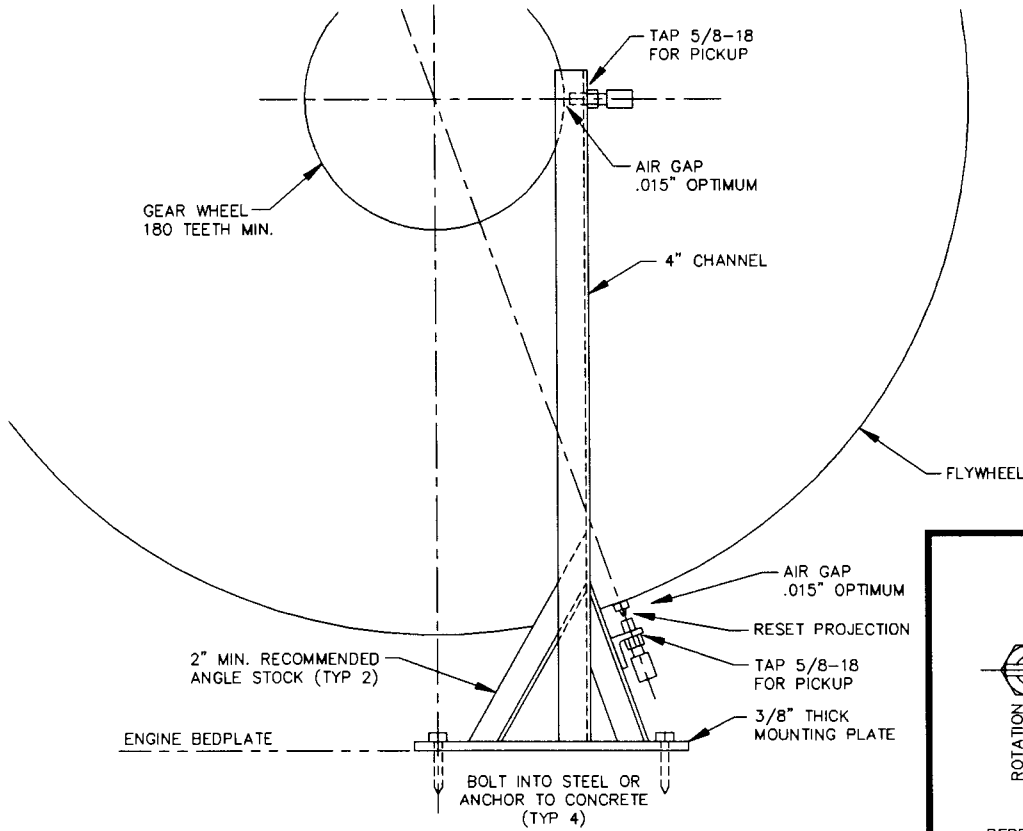

NOTE:

VISUAL PROPORTION OF THIS ILLUSTRATION
WILL CHANGE WITH VARIATIONS IN GEAR AND
FLYWHEEL SIZE AND RELATIONSHIP.

REVISIONS			
NO.	DATE	BY	DESCRIPTION
3	7-18-90	WTP	REDRAWN ON CAD; UPDATED
4			
5			
6			
7			

TOLERANCES (EXCEPT AS NOTED)
DECIMAL .XXX - ±.005 .XX - ±.010
FRACTIONAL
MATERIAL

ALTRONIC INC.			
TITLE PICKUP MOUNTING DETAIL			
DRAWN BY DA	SCALE NONE	PART NUMBER	
CHECKED BY	DATE 11-9-84	209 102	
APPROVED BY			

FLYWHEEL LAYOUT

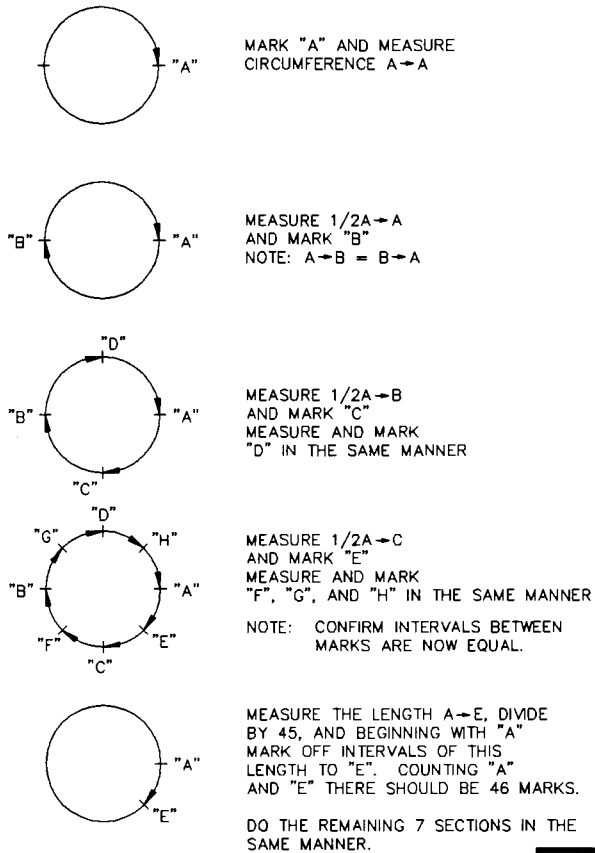

PROCEDURE FOR DRILLING 360 HOLES IN ENGINE FLYWHEEL

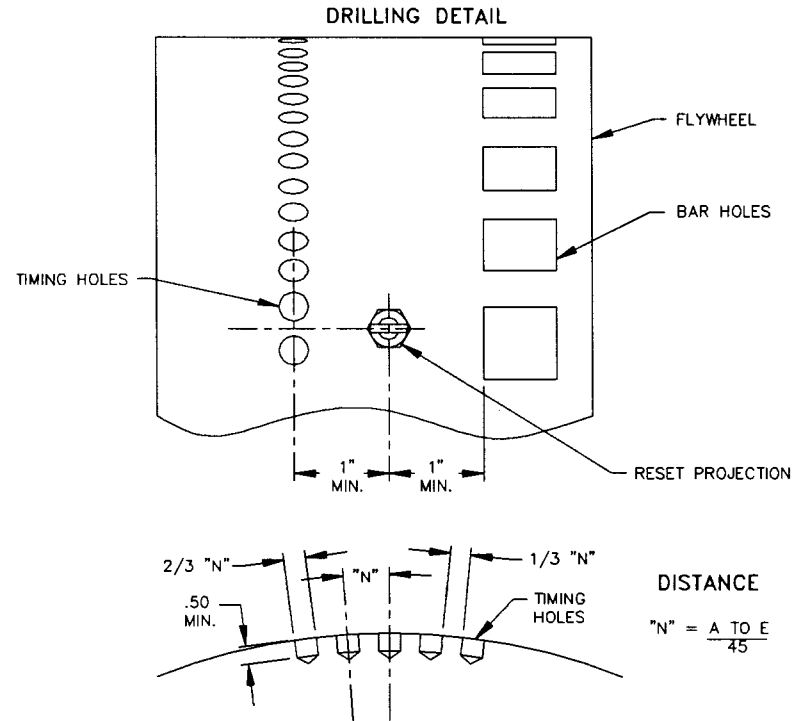

NOTE: IF 2/3 "N" WORKS OUT TO BE BETWEEN STANDARD DRILL SIZES - USE NEXT SIZE LARGER.

REVISIONS				TOLERANCES (EXCEPT AS NOTED)	ALTRONIC INC.		
NO.	DATE	BY	DESCRIPTION	DECIMAL .XXX - ±.005 .XX - ±.010	TITLE FLYWHEEL HOLE DRILLING		
1	10-19-90	WTP	REDRAWN ON CAD; UPDATED	FRACTIONAL	DRAWN BY DA	SCALE NONE	PART NUMBER
2	3-12-91	WTP	UPDATED	MATERIAL	CHECKED BY	DATE 5-29-85	209 103
3					APPROVED BY		
4							
5							

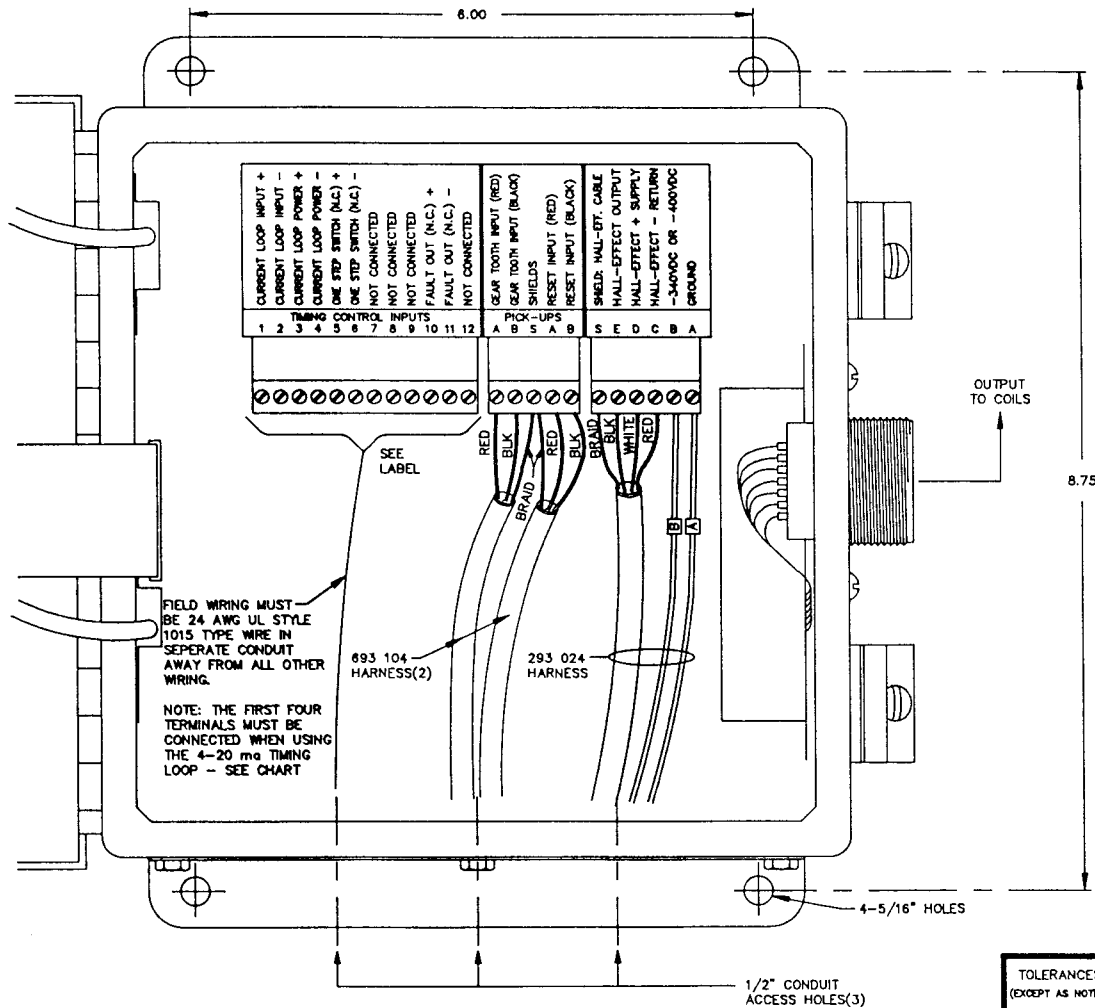

NOTE:
TERMINALS 2, 4, AND 11 ARE
ELECTRICALLY COMMON.

REVISIONS				
NO.	DATE	BY	DESCRIPTION	
1				
2				

TOLERANCES (EXCEPT AS NOTED)		ALTRONIC INC.			
DECIMAL .XXX - ±.005 .XX - ±.010		TITLE CPU CONTROL UNIT WIRING			
FRACTIONAL	DRAWN BY	WTP	SCALE	.8	PART NUMBER
MATERIAL	CHECKED BY		DATE	6-17-88	209 104A
	APPROVED BY				

* CLASS I, GROUP D, DIV. 2 RATED SYSTEM.
UNSHIELDED SPARK PLUG AND LEAD MAY BE
USED WHERE SUCH RATING IS NOT REQUIRED.

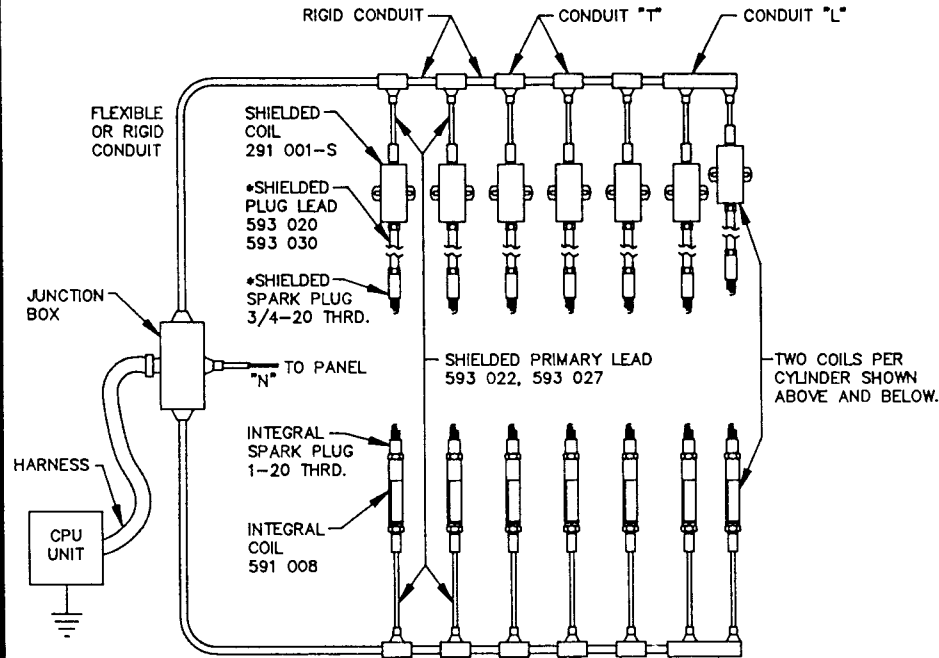

NOTE:
CPU UNIT MUST
BE GROUNDED

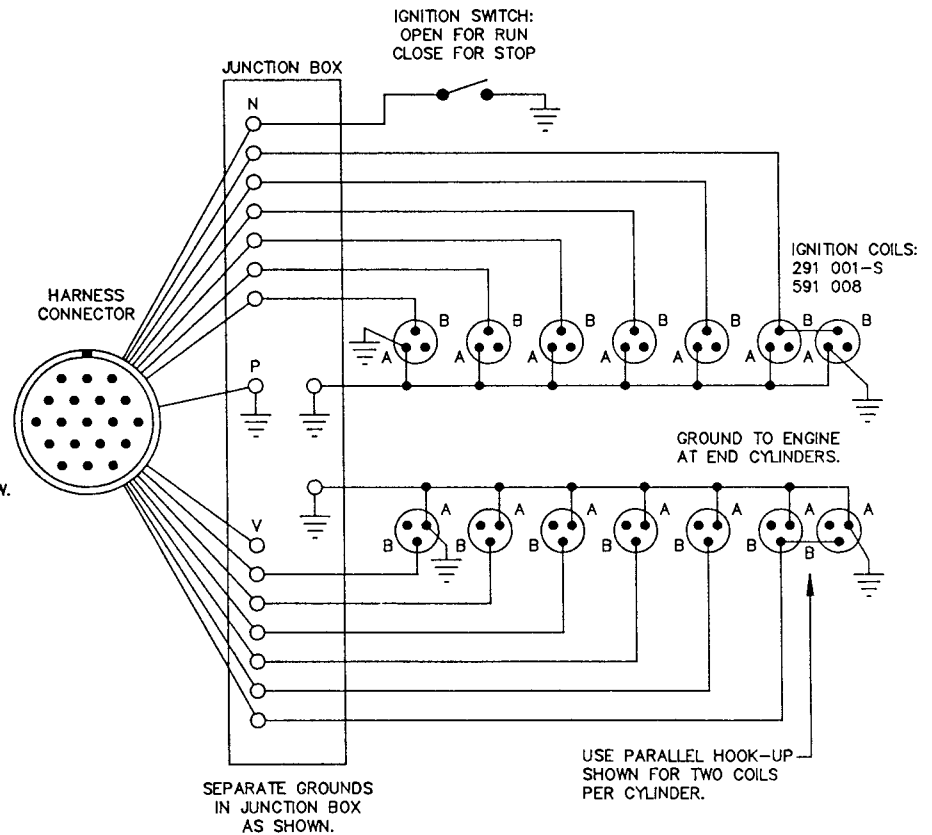

REVISIONS				TOLERANCES (EXCEPT AS NOTED)	ALTRONIC INC.				
NO.	DATE	BY	DESCRIPTION	DECIMAL .XXX - ±.005 .XX - ±.010	TITLE WIRING DIAGRAM - SHIELDED				
1	5-31-88	WTP	ADDED GROUNDS; REDRAWN ON CAD	FRACTIONAL	DRAWN BY	DB	SCALE	NONE	
2	6-15-88	DEB	DELETED GROUND NOTE	MATERIAL	CHECKED BY		DATE	5-23-85	
3	2-2-89	WTP	ADDED GROUND NOTE FOR THE CPU UNIT		APPROVED BY				
4	2-14-89	WTP	APPEARANCE OF COILS AND SPARK PLUGS CHANGED						
5									
								PART NUMBER	209 106

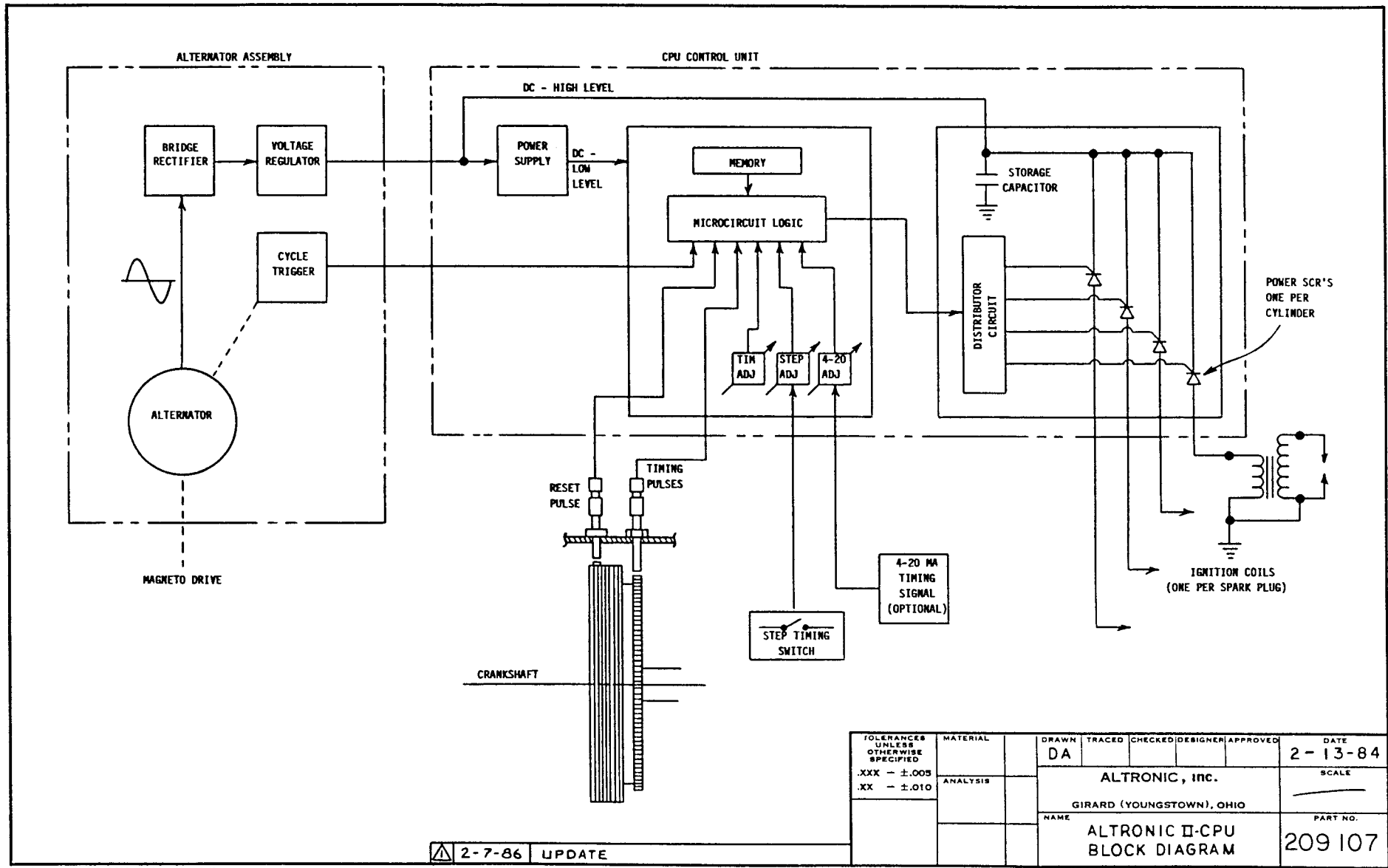

⚠ 2-7-86 UPDATE

TOLERANCES UNLESS OTHERWISE SPECIFIED .XXX - ±.005 .XX - ±.010	MATERIAL	DRAWN	TRACED	CHECKED	DESIGNER	APPROVED	DATE
	ANALYSIS	DA					2-13-84
		ALTRONIC, inc.					SCALE
		GIRARD (YOUNGSTOWN), OHIO					
		NAME	ALTRONIC II-CPU BLOCK DIAGRAM				PART NO.
							209 107

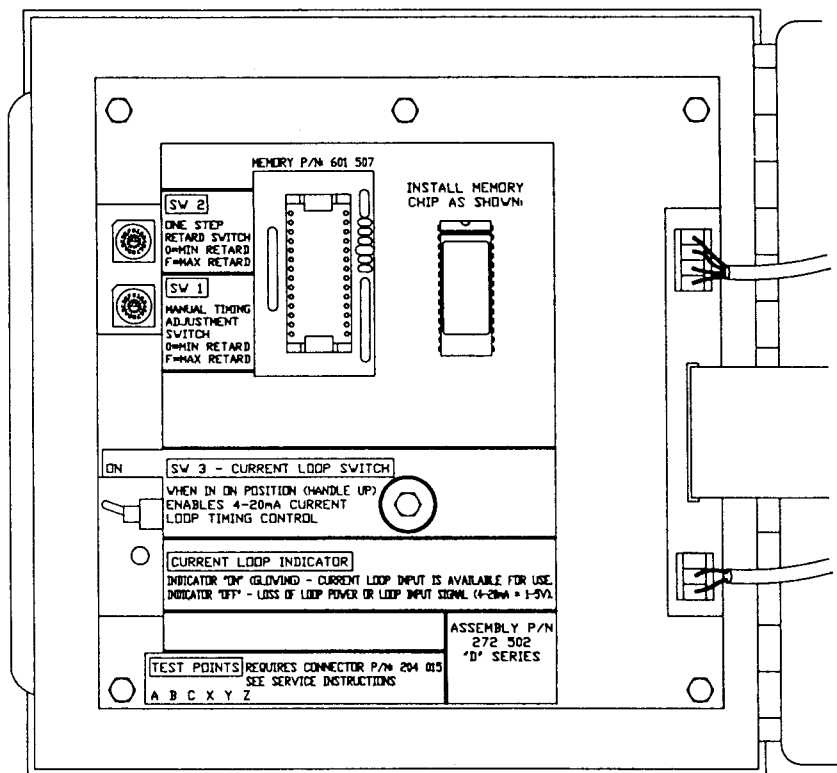

TIMING SWITCH SW1

MANUAL TIMING ADJUSTMENT USED TO SET THE FULL ADVANCE TIMING POSITION OF THE SYSTEM. POSITION 0 IS MIN. RETARD; POSITION F IS MAX. RETARD. EACH ADDITIONAL SWITCH POSITION RETARDS THE TIMING BY ONE TOOTH DEGREE.

TIMING SWITCH SW2

ONE-STEP TIMING CHANGE CONTROLLED BY EXTERNAL CONTACTS CONNECTED BETWEEN TERMINALS 5 AND 6 (SEE DRAWING 209 104A). THE EXTERNAL CONTACTS ARE NORMALLY CLOSED AND ARE OPENED TO ENABLE ADDITIONAL RETARD SET BY SW2. POSITION 0 IS MIN. RETARD; POSITION F IS MAX. RETARD. EACH ADDITIONAL SWITCH POSITION ADDS AN ADDITIONAL TOOTH DEGREE TO THE ONE-STEP TIMING CHANGE.

TIMING SWITCH SW3

CONTROLS WHETHER EXTERNAL 4-20mA CONTROL LOOP SIGNAL IS ACTIVE OR NOT. LOOP SIGNAL AND POWER ARE CONNECTED TO TERMINALS 1-4 (SEE DRAWING 209 104A). OPEN POSITION OF SW3 ALLOWS THE INFLUENCE OF THE 4-20mA LOOP; CLOSED POSITION DELETES ANY INFLUENCE FROM THE LOOP. 4mA IS MIN. RETARD, 20mA IS MAX. RETARD.

NOTES:

- 1) SWITCH SW1 IS ALWAYS OPERATIONAL. SWITCHES SW2 AND SW3, WHEN ACTIVATED, PROVIDE FOR ADDITIONAL RETARD CAPABILITY. TOTAL RETARD = RETARD SW1 + RETARD SW2 + RETARD SW3.
- 2) ON SW1 AND SW2, POSITIONS A-F REPRESENT 10-15 (TOOTH DEGREES OF RETARD).

REVISIONS				TOLERANCES (EXCEPT AS NOTED)	ALTRONIC INC.		
NO.	DATE	BY	DESCRIPTION	DECIMAL XXX - ±.005 .XX - ±.010	TITLE		PART NUMBER
1	6-15-89	WTP	NOTE '... P/N: 204 015' WAS '... P/N 204 013'	FRACTIONAL	DRAWN BY	WTP	
2				MATERIAL	CHECKED BY		DATE 5-31-88
3					APPROVED BY		209 108A
4							
5							

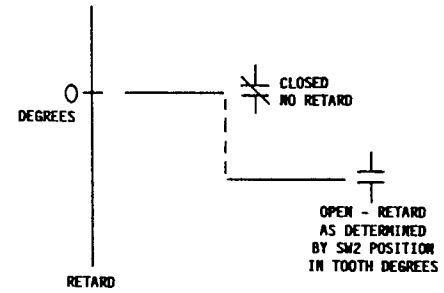
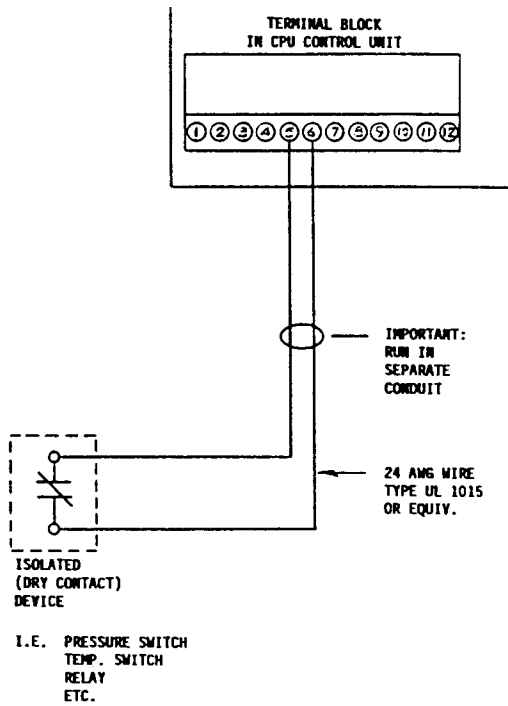

TOLERANCES UNLESS OTHERWISE SPECIFIED	MATERIAL	DRAWN	TRACED	CHECKED	DESIGNER	APPROVED	DATE
.XXX - ±.005		DA					5 - 30 - 85
.XX - ±.010	ANALYSIS	ALTRONIC, inc.					SCALE
		GIRARD (YOUNGSTOWN), OHIO					
		NAME					PART NO.
		TIMING CURVE					209109
		ONE - STEP					

TO SHORTEN HARNESS

1. LOOSEN AND DISENGAGE NUT (2) AND REMOVE CONDUIT (1) COMPLETELY FROM CONNECTOR AND HARNESS ASSEMBLY (3).
2. REMOVE ITEMS (5), (4), AND (2) IN THAT ORDER FROM CONDUIT (1). NOTE THREADS ON (5).
3. CUT CONDUIT TO LENGTH WITH HACKSAW AND DRESS WITH FILE TO INSURE A CLEAN, SQUARE END. REMOVE FILINGS FROM INSIDE CONDUIT.
4. REINSTALL ITEMS (2), (4), AND (5) IN THAT ORDER.
5. INSTALL REASSEMBLED CONDUIT INTO (3) AND TIGHTEN (2).

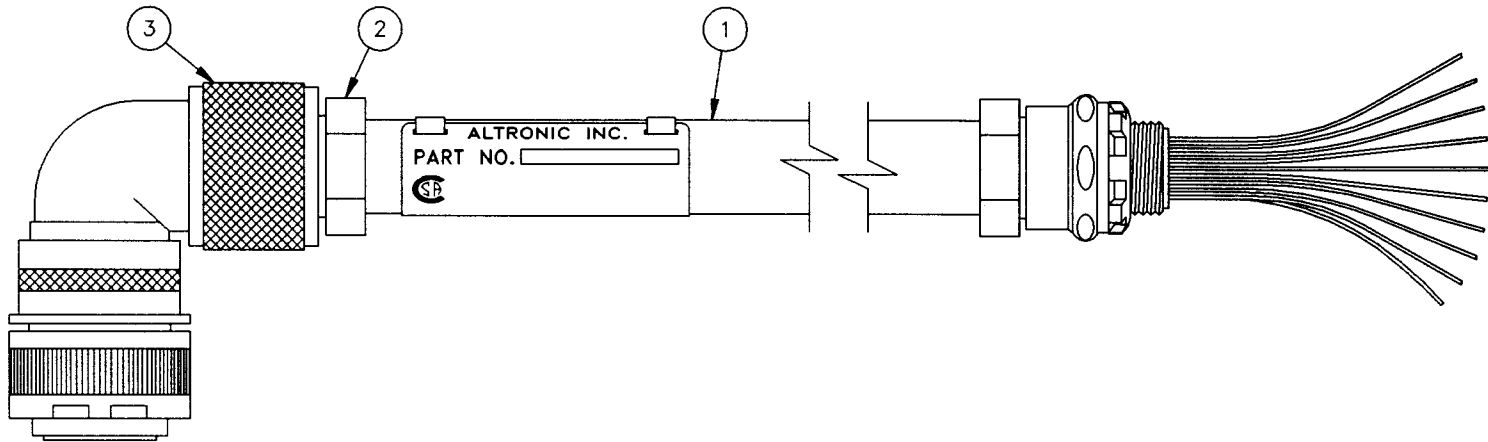
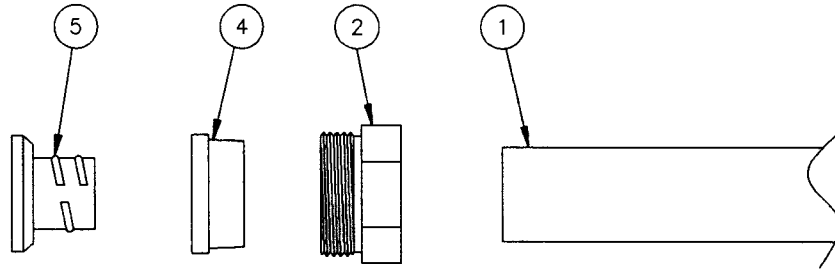

REVISIONS				TOLERANCES (EXCEPT AS NOTED)		ALTRONIC INC.			
NO.	DATE	BY	DESCRIPTION	DECIMAL		TITLE			
1	3-14-92	WTP	REDRAWN ON CAD	.XXX	± .005	SHIELDED HARNESS CONDUIT LENGTH ADJUSTMENT		DRAWN BY DWA SCALE NONE PART NUMBER	
2				.XX	± .010				
3				FRACTIONAL		CHECKED BY	DATE	5-28-85	
4				MATERIAL		APPROVED BY		509 025	
5									